

#80982 & #80983 - Light Canister Set

Package Contents:

- 1 - Mounting Plate
- 4 - Light Canisters
- 4 - Clear Lenses
- 4 - Light Guards
- 4 - M3 x 8mm Flathead Screws

Installation: (Requires an RPM Front Bumper - #70902, #70905, #73042, #80022, #80023, #80025, #80952, #80953 or #80955):

1) Carefully clip all parts from their respective parts trees.

2) (#80983 only) If you intend to install the lenses, scrape the chrome off of the inside shoulder of each canister as noted in the illustration. If the Light Guards will be used, sand the front surface of each canister with 600 grit sand paper until the chrome is gone. Scrape off the chrome from the back edge of the Light Guards as well, using caution not to remove the alignment shoulders.

3) If you intend to install LED lights, slip a 3mm LED into the center hole **from the back** of each canister **before** screwing the canisters to the mounting plate (review the LED instructions on the back of this instruction sheet for important details). Using the included flathead screws, screw the four canisters to the mounting plate until snug. **Caution:** Do not overtighten the screws!

4) You have the option of running the canisters as is - no lenses or guards, with or without the lenses and with or without the guards. If you wish to use the lenses, use either model cement or a pliable silicone glue (preferred) and place a small amount of adhesive on the shoulder of the canister then press the lens onto that shoulder fully (the lens must rest on the shoulder fully otherwise the guard won't seat properly). Be extremely cautious with the lenses. They can crack if too much pressure is applied. If you wish to use the guards, place a small amount of adhesive on the front face of the canister and press the guard in place, using caution to orient the guard any way you prefer before the glue sets up. Allow the adhesive to cure fully before proceeding.

5) If you have the **RPM** Slash front bumper installed on your truck, remove it now and separate the skid plate from the bumper. Place the Mounting Plate / light assembly on the **inside** of the skid plate (not between the bumper and skid plate) and slide the screws (that came with your **RPM** front bumper / skid plate) through the Mounting Plate, then through the skid plate and into the front bumper. The front edge of the canisters should sit back from the front of the bumper once the screws are tightened. Once again, do not overtighten the screws. Finally, reinstall the bumper / skid plate to the front of your truck.

Warranty Notes: Due to the scale appearance of this light canister set, we cannot properly strengthen all aspects of the lights. Therefore, the following limitations on our warranty apply. The lenses and light guards are not covered against breakage although normal material and workmanship coverage is still applicable. The canisters and light mount retain normal **RPM** warranty protection when installed as covered in this instruction sheet.

LED Lights: Please see the reverse side of this instruction sheet for instructions on how to install 3mm LED's in the **RPM Light Canister Set**.

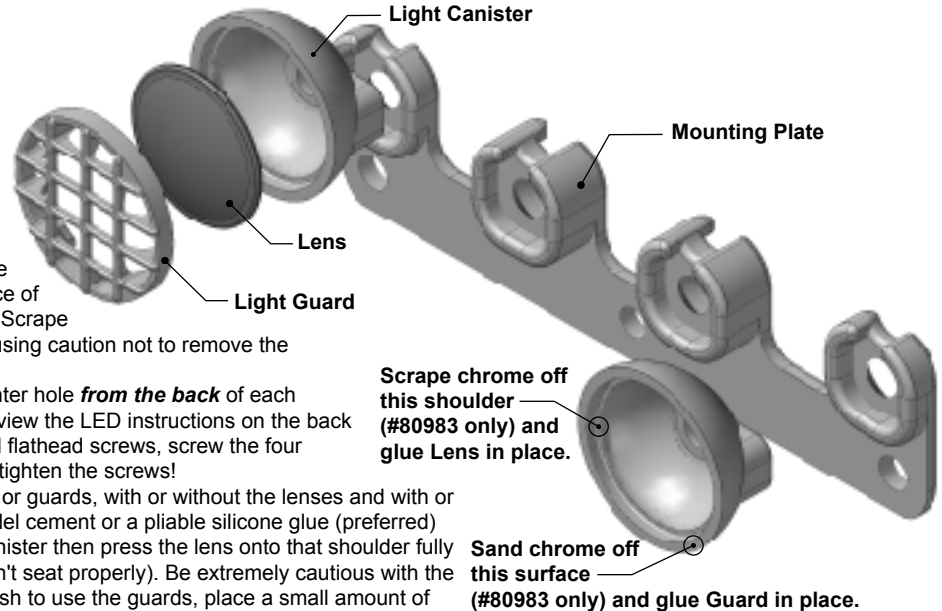

How to Install LED's in RPM Light Canisters

What's Needed:

4 - 3mm LED's 4 - Resistors (See below)
1 - On / Off Switch 1 - Wire Connector (See below)
1 - Receiver Plug 22 AWG Wire or similar

1) Our numbers throughout this installation are based on **3mm LED lights** with the following specifications: **3.2Vf @ 20mA w/ 3200 mcd**. We used Linrose Super Bright White LED's with PN - **BCMD204UWC**. We used NTE $\frac{1}{4}$ W 150ohm resistors with PN - **QW115** as well.

2) Our ON / OFF switch, wire connector and receiver plug were taken from an old transmitter but you can find inexpensive options at your local hobby shop. Make sure your receiver plug is designed to fit your model receiver. The illustration to the right is based on a stock Traxxas receiver.

3) At Step #3 on the reverse side, you are asked to slip a 3mm LED into each canister. Be sure to check the polarity of each of your LED's and arrange all four in the canisters identically. Review the LED package to determine which lead is + and which is negative. Once that's done, finish the installation of the canisters **and come back to this point when it's finished.**

4) Find a place for your ON / OFF switch. We chose to mount ours on top of the receiver box for easy access, We also used double-sided servo tape to keep it in place.

5) Run the + wire of the switch to the + wire of the receiver plug then run the - wire of the switch to the - wire of the receiver plug.

Caution: Check and double-check the polarity of the receiver plug's orientation. Crossing the polarity of the wires can destroy your receiver. The receiver plug will press into the **BATT / CH4** slot of the receiver.

6) Install a connector of your choice after the switch to allow the LED's to be removed without removing the switch and receiver wires.

7) At this point, you will need to solder 4 wires together to split both the + & - wires exiting the connector, giving you 8 wires (4 positive & 4 neg.),

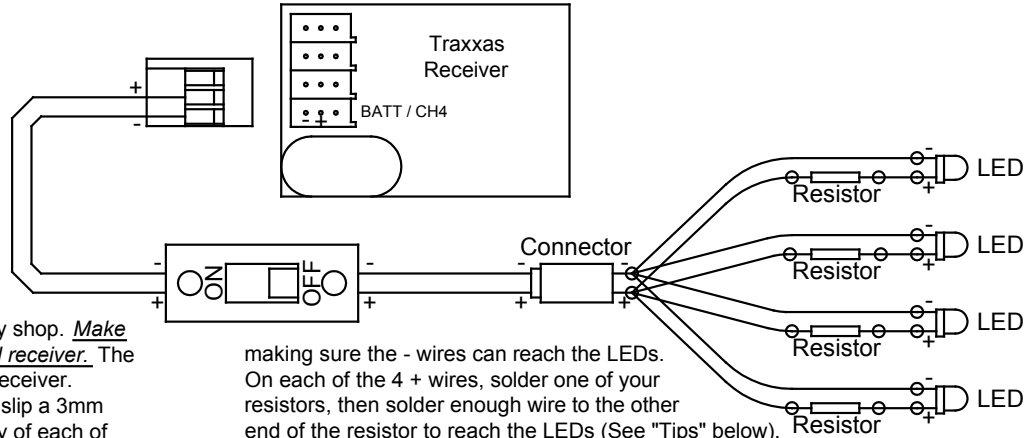

making sure the - wires can reach the LEDs.

On each of the 4 + wires, solder one of your resistors, then solder enough wire to the other end of the resistor to reach the LEDs (See "Tips" below).

Keep in mind that you'll want to route the wires along the side of the skid plate to prevent the sharp edges of the body from cutting the wires while running the truck.

8) Solder the ends of your 4 - wires to the negative leads of your 4 LED's.

9) Clip the LED leads as close to your wires as possible for body clearance.

10) Use electrical tape or shrink-wrap on all exposed connections.

11) Plug in a battery and test the lights. If something isn't working, the first place to look is the polarity of the LED's. Polarity is the main source of problems. Don't forget to recheck your wires' polarity too.

TIPS: a) Solder the resistors as close as you can to the LED's (but far enough away so the body doesn't rub on them, then try to keep the 8 positive & negative LED wires as short as possible before merging them into the connector listed in Step #6. This will keep excess wire to a minimum. **b)** Try twisting each pair of LED wires together. This makes them easier to route and less likely to flop around while driving. **c)** If you'd like to run a separate 9V battery instead of running the lights through the BEC circuit off of the main battery pack, simply replace each resistor with a 330 ohm version and replace the receiver connector with a 9V connector.