

S3170G RETRACT SERVO

The S3170G is low-speed operation, high torque specifications for the retractable landing gear of model airplanes. It has a function that prevents overheating of the motor by an external load demanded of a servo for retractable landing gear.

It has a function that automatically prevents overheating of the motor by an external overload and prevents the servo from moving if a change in the signal input is not detected for 30 seconds after operation when the servo was operated within a range of approximately 60° to the left or right of the neutral point.

When a signal change is sensed, the servo immediately returns to normal operation and operates like a general servo. Since this function operates within an operating angle range of within 60° to the left or right of the neutral point, it can be used like a general servo within an operating range of 60° to the left or right.

Landing gear retraction switch operation of general transmitters has an operating angle of approximately 180°. With transmitters having a servo operating angle end point adjustment function the servo stop position can be adjusted by adjusting the operating angle end point. (Since the operating angle of the 14MZ, 12MZ, and 12FG transmitters is 150°, perform end point adjustment.)

⚠ CAUTION [Usage precautions]

- Use this servo within the specified power supply voltage range.
- Since the retractable landing gear mechanism operates within a normal operating range of approximately 60° to the left and right do not leave it with a continuous load applied.
- Since the servo does not enter the landing gear retraction mode if 30 seconds have not elapsed after the motor stops even in a range exceeding 60° to the left or right, connect the linkage so that a load is not applied to the motor when the servomotor was stopped.
- Since the gear ratio was made extremely large to perform low speed operation; the servo may be destroyed if turned with unreasonable force from the servo horn side.
- Before connecting the linkage always connect the transmitter and receiver and check the servo stop position.
- Do not remove and reconstruct the servo connector. If the power supply is reversed, there is the possibility of smoke, fire, and damage.

RETRACT SERVO INSTRUCTION MANUAL

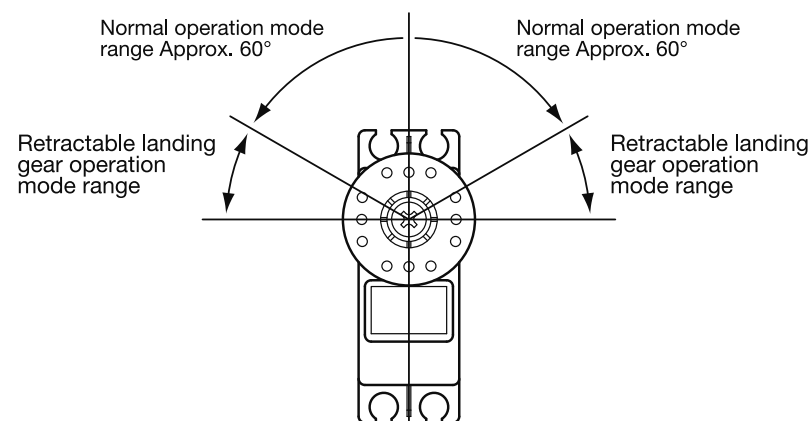

- **Speed**
0.57 sec/60° at 4.8V
0.47 sec/60° at 6.0V
- **Torque**
7.0 kg-cm (97.2 oz-in) at 4.8V
8.5 kg-cm (118.1 oz-in) at 6.0V
- **Size**
34.5 x 16.0 x 25.8 mm (1.36 x 0.63 x 1.02 in)
- **Weight**
26 g (0.92 oz)

Planetary Gear Servo

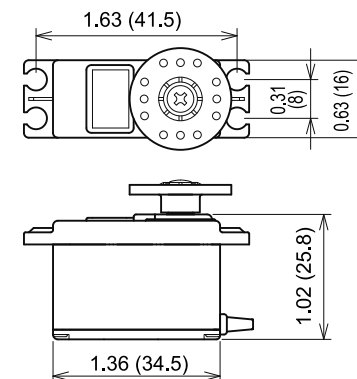

Unit : in (mm)

※ Use the horn set screw supplied with the servo.
(Screw size: 3x8mm)