

1/10 LUXURY ELECTRIC OFF-ROAD BUGGY 4WD

XRAY XB4

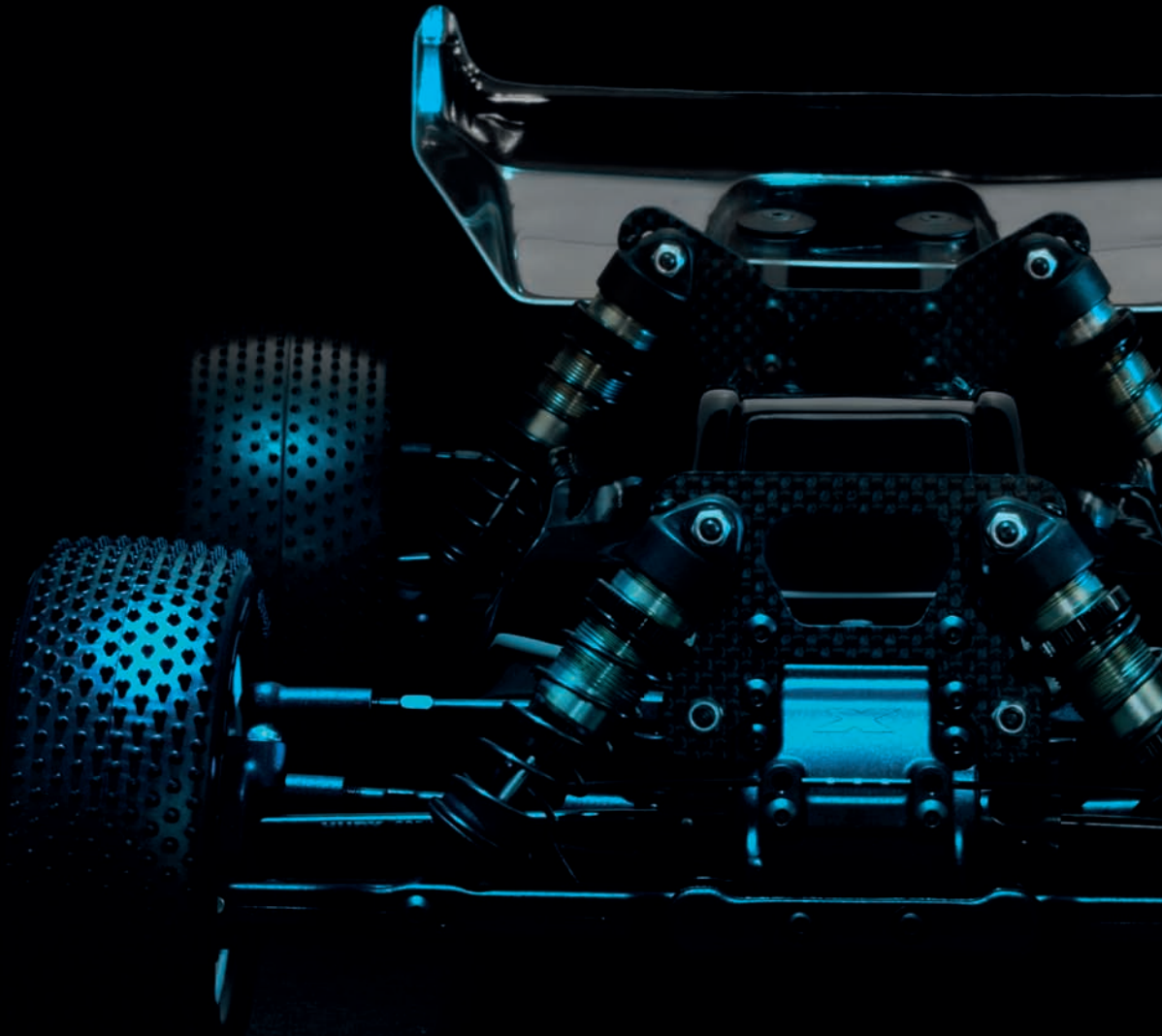

INSTRUCTION MANUAL
FOR XB4'20 EDITION

BEFORE YOU START

This is a high-competition, high-quality RC car intended for persons aged 16 years and older with previous experience building and operating RC model racing cars. This is not a toy; it is a precision racing model. This model racing car is not intended for use by beginners, inexperienced customers, or by children without direct supervision of a responsible, knowledgeable adult. If you do not fulfill these requirements, please return the kit in unused and unassembled form back to the shop where you have purchased it.

Before building and operating your XRAY, **YOU MUST** read through all of the operating instructions and instruction manual and fully understand them to get the maximum enjoyment and prevent unnecessary damage.

CUSTOMER SUPPORT

We have made every effort to make these instructions as easy to understand as possible. However, if you have any difficulties, problems, or questions, please do not hesitate to contact the XRAY support team at info@teamxray.com. Also, please visit our Web site at www.teamxray.com to find the latest updates, set-up information, option parts, and many other goodies. We pride ourselves on taking excellent care of our customers.

You can join thousands of XRAY fans and enthusiasts in our online community at: www.teamxray.com

Read carefully and fully understand the instructions before beginning assembly.

Make sure you review this entire manual, download and use set-up book from the web, and examine all details carefully. If for some reason you decide this is not what you wanted or expected, **do not continue any further**. Your hobby dealer can not accept your kit for return or exchange after it has been partially or fully assembled.

Contents of the box may differ from pictures. In line with our policy of continuous product development, the exact specifications of the kit may vary without prior notice.

XRAY Europe

K Vystavisku 6992
91101 Trenčín
Slovakia, EUROPE
Phone: 421-32-7401100
Fax: 421-32-7401109
E-mail: info@teamxray.com

XRAY USA

RC America, 2030 Century Center Blvd #15
Irving, TX 75062
USA
Phone: (214) 744-2400
Fax: (214) 744-2401
E-mail: xray@rcamerica.com

FAILURE TO FOLLOW THESE INSTRUCTIONS WILL BE CONSIDERED AS ABUSE AND/OR NEGLECT.

SAFETY PRECAUTIONS

Contains:

LEAD (CAS 7439-92-1) ANTIMONY (CAS 7440-36-0)

WARNING: This product contains a chemical known to the state of California to cause cancer and birth defects or other reproductive harm.

CAUTION: CANCER HAZARD

Contains lead, a listed carcinogen. Lead is harmful if ingested. Wash thoroughly after using. DO NOT use product while eating, drinking or using tobacco products. May cause chronic effects to gastrointestinal tract, CNS, kidneys, and blood. MAY CAUSE BIRTH DEFECTS.

When building, using and/or operating this model always wear protective glasses and gloves.

Take appropriate safety precautions prior to operating this model. You are responsible for this model's assembly and safe operation! Please read the instruction manual before building and operating this model and follow all safety precautions. Always keep the instruction manual at hand for quick

reference, even after completing the assembly. Use only genuine and original authentic XRAY parts for maximum performance. Using any third party parts on this model will void guaranty immediately.

Improper operation may cause personal and/or property damage. XRAY and its distributors have no control over damage resulting from shipping, improper construction, or improper usage. XRAY assumes and accepts no responsibility for personal and/or property damages resulting from the use of improper building materials, equipment and operations. By purchasing any item produced by XRAY, the buyer expressly warrants that he/she is in compliance with all applicable federal, state and local laws and regulation regarding the purchase, ownership and use of the item. The buyer expressly agrees to indemnify and hold harmless XRAY for all claims resulting directly or indirectly from the purchase, ownership or use of the product. By the act of assembling or operating this product, the user accepts all resulting liability. If the buyer is not prepared to accept this liability, then he/she should return this kit in new, unassembled, and unused condition to the place of purchase.

IMPORTANT NOTES - GENERAL

- This product is not suitable for children under 16 years of age without the direct supervision of a responsible and knowledgeable adult.
- Carefully read all manufacturers warnings and cautions for any parts used in the construction and use of your model.
- Assemble this kit only in places away from the reach of very small children.
- First-time builders and users should seek advice from people who have building experience in order to assemble the model correctly and to allow the model to reach its performance potential.
- Exercise care when using tools and sharp instruments.
- Take care when building, as some parts may have sharp edges.
- Keep small parts out of reach of small children. Children must not be allowed to put any parts in their mouth, or pull vinyl bag over their head.
- Read and follow instructions supplied with paints and/or cement, if used (not included in kit).
- Immediately after using your model, do NOT touch equipment on the model such as the motor and speed controller, because they generate high temperatures. You may seriously burn yourself seriously touching them.
- Follow the operating instructions for the radio equipment at all times.
- Do not put fingers or any objects inside rotating and moving parts, as this may cause damage or serious injury as your finger, hair, clothes, etc. may get caught.
- Be sure that your operating frequency is clear before turning on or running your model, and never share the same frequency with somebody else at the same time. Ensure that others are aware of the operating frequency you are using and when you are using it.
- Use a transmitter designed for ground use with RC cars. Make sure that no one else is using the same frequency as yours in your operating area. Using the same frequency at the same time, whether it is driving, flying or sailing, can cause loss of control of the RC model, resulting in a serious accident.
- Always turn on your transmitter before you turn on the receiver in the car. Always turn off the receiver before turning your transmitter off.
- Keep the wheels of the model off the ground when checking the operation of the radio equipment.
- Disconnect the battery pack before storing your model.
- When learning to operate your model, go to an area that has no obstacles that can damage your model if your model suffers a collision.
- Remove any sand, mud, dirt, grass or water before putting your model away.
- If the model behaves strangely, immediately stop the model, check and clear the problem.
- To prevent any serious personal injury and/or damage to property, be responsible when operating all remote controlled models.
- The model car is not intended for use on public places and roads or areas where its operation can conflict with or disrupt pedestrian or vehicular traffic.
- Because the model car is controlled by radio, it is subject to radio interference from many sources that are beyond your control. Since radio interference can cause momentary loss of control, always allow a safety margin in all directions around the model in order to prevent collisions.
- Do not use your model:
 - Near real cars, animals, or people that are unaware that an RC car is being driven.
 - In places where children and people gather
 - In residential districts and parks
 - In limited indoor spaces
 - In wet conditions
 - In the street
 - In areas where loud noises can disturb others, such as hospitals and residential areas.
 - At night or anytime your line of sight to the model may be obstructed or impaired in any way.

To prevent any serious personal injury and/or damage to property, please be responsible when operating all remote controlled models.

IMPORTANT NOTES – ELECTRICAL

- Insulate any exposed electrical wiring (using heat shrink tubing or electrical tape) to prevent dangerous short circuits. Take maximum care in wiring, connecting and insulating cables. Make sure cables are always connected securely. Check connectors for if they become loose. And if so, reconnect them securely. Never use RC models with damaged wires. A damaged wire is extremely dangerous, and can cause short-circuits resulting in fire. Please have wires repaired at your local hobby shop.
- Low battery power will result in loss of control. Loss of control can occur due to a weak battery in either the transmitter or the receiver. Weak running battery may also result in an out of control car if your car's receiver power is supplied by the running battery. Stop operation immediately if the car starts to slow down.
- When not using RC model, always disconnect and remove battery.
- Do not disassemble battery or cut battery cables. If the running battery short-circuits, approximately 300W of electricity can be discharged, leading to fire or burns. Never disassemble battery or cut battery cables.
- Use a recommended charger for the receiver and transmitter batteries and follow the instructions correctly. Over-charging, incorrect charging,

- or using inferior chargers can cause the batteries to become dangerously hot. Recharge battery when necessary. Continual recharging may damage battery and, in the worst case, could build up heat leading to fire. If battery becomes extremely hot during recharging, please ask your local hobby shop for check and/or repair and/or replacement.
- Regularly check the charger for potential hazards such as damage to the cable, plug, casing or other defects. Ensure that any damage is rectified before using the charger again. Modifying the charger may cause short-circuit or overcharging leading to a serious accident. Therefore do not modify the charger.
- Always unplug charger when recharging is finished.
- Do not recharge battery while battery is still warm. After use, battery retains heat. Wait until it cools down before charging.
- Do not allow any metal part to short circuit the receiver batteries or other electrical/electronic device on the model.
- Immediately stop running if your RC model gets wet as may cause short circuit.
- Please dispose of batteries responsibly. Never put batteries into fire.

R/C & BUILDING TIPS

- Make sure all fasteners are properly tightened. Check them periodically.
- Make sure that chassis screws do not protrude from the chassis.
- For the best performance, it is very important that great care is taken to ensure the free movement of all parts.
- Clean all ball-bearings so they move very easily and freely.
- Tap or pre-thread the plastic parts when threading screws.
- Self-tapping screws cut threads into the parts when being tightened. Do not use excessive force when tightening the self-tapping screws because you may strip out the thread in the plastic. We recommended you stop tightening a screw when you feel some resistance.
- Ask your local hobby shop for any advice.

Please support your local hobby shop. We at XRAY Model Racing Cars support all local hobby dealers. Therefore we ask you, if at all possible, to purchase XRAY products at your hobby dealer and give them your support like we do. If you have difficulty finding XRAY products, please check out www.teamxray.com to get advice, or contact us via email at info@teamxray.com, or contact the XRAY distributor in your country.

WARRANTY

XRAY guarantees this model kit to be free from defects in both material and workmanship within 30 days of purchase. The total monetary value under warranty will in no case exceed the cost of the original kit purchased. This warranty does not cover any components damaged by use or modification or as a result of wear. Part or parts missing from this kit must be reported within 30 days of purchase. No part or parts will be sent under warranty without proof of purchase. Should you find a defective or missing part, contact the local distributor. Service and customer support will be provided through local hobby store where you have purchased the kit, therefore make sure to purchase any XRAY products at your local hobby store. This model racing car is considered to be a high-performance racing vehicle. As such this vehicle will be used in an extreme range of conditions and situations, all which may cause premature wear or failure of any component. XRAY has no control over usage of vehicles once they leave the dealer, therefore XRAY can only offer warranty against all manufacturer's defects in materials, workmanship, and assembly at point of sale and before use. No warranties are expressed or implied that cover damage caused by what is considered normal use, or cover or imply how long any model cars' components or electronic components will last before requiring replacement.

Due to the high performance level of this model car you will need to periodically maintain and replace consumable components. Any and all warranty coverage will not cover replacement of any part or component damaged by neglect, abuse, or improper or unreasonable use. This includes

but is not limited to damage from crashing, chemical and/or water damage, excessive moisture, improper or no maintenance, or user modifications which compromise the integrity of components. Warranty will not cover components that are considered consumable on RC vehicles. XRAY does not pay nor refund shipping on any component sent to XRAY or its distributors for warranty. XRAY reserves the right to make the final determination of the warranty status of any component or part.

Limitations of Liability

XRAY makes no other warranties expressed or implied. XRAY shall not be liable for any loss, injury or damages, whether direct, indirect, special, incidental, or consequential, arising from the use, misuse, or abuse of this product and/or any product or accessory required to operate this product. In no case shall XRAY's liability exceed the monetary value of this product.

Take adequate safety precautions prior to operating this model. You are responsible for this model's assembly and safe operation.

Disregard of the any of the above cautions may lead to accidents, personal injury, or property damage. XRAY MODEL RACING CARS assumes no responsibility for any injury, damage, or misuse of this product during assembly or operation, nor any additions that may arise from the use of this product.

All rights reserved.

QUALITY CERTIFICATE

XRAY MODEL RACING CARS uses only the highest quality materials, the best compounds for molded parts and the most sophisticated manufacturing processes of TQM (Total Quality Management). We guarantee that all parts of a newly-purchased kit are manufactured with the highest regard to quality. However, due to the many factors inherent in model racecar competition, we

















cannot guarantee any parts once you start racing the car. Products which have been worn out, abused, neglected or improperly operated will not be covered under warranty.

We wish you enjoyment of this high-quality and high-performance RC car and wish you best success on the track!

In line with our policy of continuous product development, the exact specifications of the kit may vary. In the unlikely event of any problems with your new kit, you should contact the model shop where you purchased it, quoting the part number.

We do reserve all rights to change any specification without prior notice. All rights reserved.





SYMBOLS USED

<p>Part bags used</p> 	<p>Assemble in the specified order</p> 	<p>Assemble left and right sides the same way</p> 	<p>Pay attention here</p> 	<p>Assemble as many times as specified (here twice)</p> 	<p>Apply threadlock</p> 	<p>Apply CA glue</p> 	<p>Apply oil</p> 
<p>Scale</p> 	<p>Apply grease</p> 	<p>Optional parts</p> 	<p>Ensure smooth non-binding movement</p> 	<p>Tighten screw gently</p> 	<p>Completed assembly</p> 	<p>Detail</p> 	<p>Apply cleaner</p> 













TOOLS REQUIRED

<p>Scissors (HUDY #188990)</p> 	<p>Special Tool for turnbuckles, nuts (HUDY #181090)</p> 	<p>Turnbuckle Wrench 3mm (HUDY #181030)</p> 	<p>Pocket Hobby Knife (HUDY #188981)</p> 	<p>Side Cutters (HUDY #189010)</p> 	<p>Combination Pliers (HUDY #189020)</p> 	<p>RC Shock-Plier Uni Tool (HUDY #183011)</p> 
<p>Tweezer</p> 	<p>HUDY TOOLS:</p> <p>Allen 1.5mm </p> <p>Allen 2.0mm </p> <p>Socket 5.5mm </p> <p>Socket 7.0mm </p>			<p>Arm Reamer 3.0mm </p> <p>Reamer (HUDY #107600) or (HUDY #107601) </p>		

ITEMS INCLUDED

<p>HUDY Premium Silicone Oils Oil 500cSt (#106350)</p> 	<p>HUDY Premium Silicone Oils Oil 700cSt (#106370)</p> 	<p>HUDY Premium Silicone Oils Oil 10.000cSt (#106510)</p> 	<p>Graphite Grease (HUDY #106210)</p> 
--	--	---	---

EQUIPMENT REQUIRED

<p>Transmitter</p> 	<p>Receiver</p> 	<p>Steering Servo</p> 	<p>Electric Motor & Pinion Gear with Set-screw</p> 	<p>Bearing Oil (HUDY #106230)</p> 	<p>CA glue</p> 
<p>Speed Controller</p> 	<p>LiPo Battery</p> 	<p>Lexan™ Paint</p> 	<p>Battery Charger</p> 	<p>Double-sided Tape (HUDY #107875)</p> 	<p>Tires & Inserts</p> 

NOT INCLUDED

Set-up Book

To ensure that you always have access to the most up-to-date version of the HUDY Set-up Book, you can download it from the HUDY website at [www.hudy.net]. By offering this online version instead of including a hardcopy printed version in kits, you will always be assured of having the most current updated version.



XRAY offers wide range of optional tuning parts which are listed in tables like these. Please refer to the exploded view of each main section to verify which part is included in the kit while all other parts are available only as an optional part and must be purchased separately.



SAMPLE OF OPTIONAL PARTS

OPTION	#36XXXX	TYPE	OPTION 1
	#36XXXX	TYPE	OPTION 2
	#36XXXX	TYPE	INCLUDED
	#36XXXX	TYPE	OPTION 3

COLOR INDICATIONS

At the beginning of each section is an exploded view of the parts to be assembled. There is also a list of all the parts and part numbers that are related to the assembly of that section.

The part descriptions are color-coded to make it easier for you to identify the source of a part. Here are what the different colors mean:

365884

STYLE A - indicates parts that are included in the bag marked for the section.

361100

STYLE B - indicates parts that are included in the box.

364900

STYLE C - indicates parts that are already assembled from previous steps.

XB4 TECH TIPS

TIP DRIVE SHAFT PIN SERVICING

To enjoy the longest possible lifespan of the drive shafts and diff outdrives, it is extremely important to properly service the drive shaft pins. Inspect the pins after every 3 hours of runtime. If the pins show any wear, replace them with new pins.



Do not use drive shafts when the pins are worn.

Press out the worn pins.

Press in new pins and regularly inspect for wear.



For quick & easy drive pin replacements use #106000 HUDY Drive Pin Replacement Tool together with #106036 Ejector Pivot Pin & Alternating Pivot 2.5mm.



To replace the worn pins use only premium HUDY drive pins (#106051 3.0mm dia x 10mm length) (#106053 2.5mm dia x 10mm length)

TIP GRAPHITE PARTS PREPARATION

Follow this Tech Tip to prepare the graphite parts. Sand the edges with sandpaper, and then seal the edges with CA glue to reinforce them and help prevent delamination.

Prepare all XB4 Graphite Parts:

- Front shock tower
- Rear shock tower

Fine sandpaper

Use fine sandpaper to sand smooth the edges of all graphite parts.

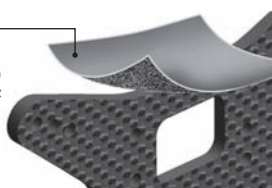

Apply CA glue to all edges of the graphite parts.

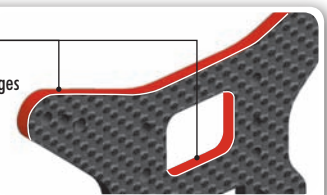

1. FRONT & REAR DIFFERENTIAL

#364941
OPTION
 STEEL DIFFERENTIAL BEVEL GEAR
 FOR LARGE VOLUME DIFF 41T

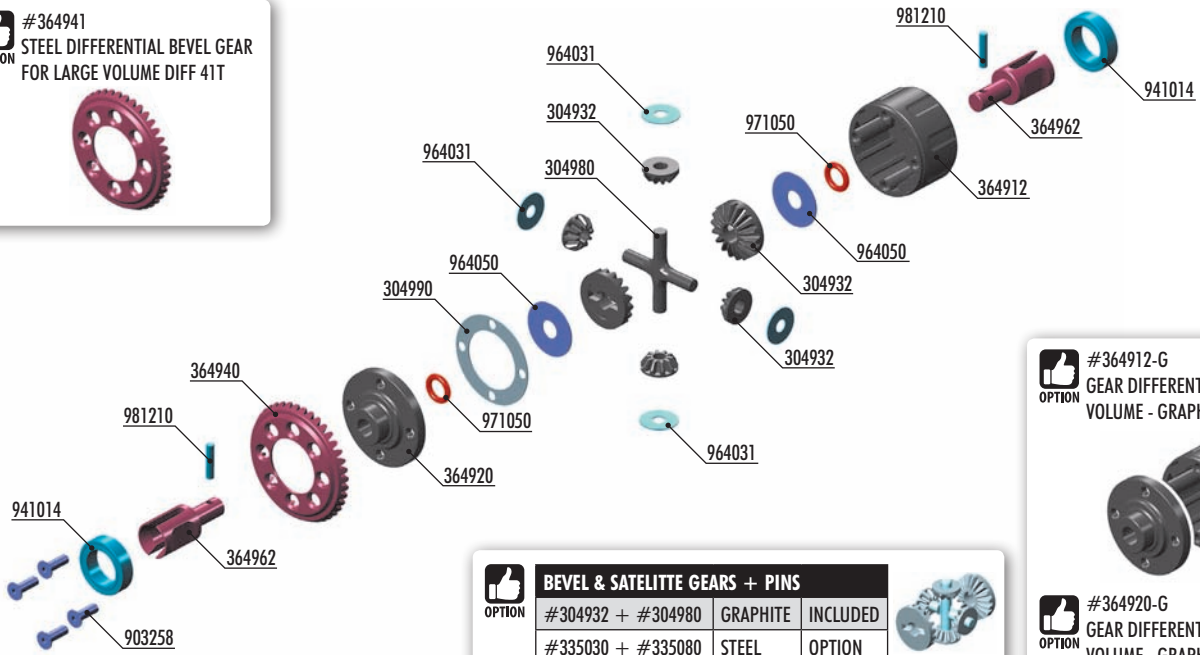

BEVEL & SATELLITE GEARS + PINS		
#304932 + #304980	GRAPHITE	INCLUDED
#335030 + #335080	STEEL	OPTION

#364912-G
OPTION
 GEAR DIFFERENTIAL CASE - LARGE
 VOLUME - GRAPHITE



#364920-G
OPTION
 GEAR DIFFERENTIAL COVER - LARGE
 VOLUME - GRAPHITE



304932	GRAPHITE GEAR DIFF BEVEL & SATELLITE GEARS (2+4)	364962	GEAR DIFF OUTDRIVE ADAPTER FOR LARGE VOLUME DIFF (2)
304980	COMPOSITE GEAR DIFF CROSS PIN	903258	HEX SCREW SFH M2.5x8 (10)
304990	DIFF GASKET (4)	941014	BALL-BEARING 10x15x4 RUBBER SEALED - GREASE (8)
364903	GEAR DIFFERENTIAL - LARGE VOLUME - SET	964031	WASHER S 3.5x10x0.2 (10)
364912	COMPOSITE GEAR DIFFERENTIAL CASE - LARGE VOLUME	964050	WASHER S 5x15x0.3 (10)
364920	COMPOSITE GEAR DIFFERENTIAL COVER - LARGE VOLUME	971050	SILICONE O-RING 5x1.5 (10)
364940	STEEL DIFFERENTIAL BEVEL GEAR FOR LARGE VOLUME DIFF 40T	981210	PIN 2x10 (10)



964050
S 5x15x0.3



971050
O 5x1.5

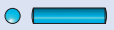

981210
P 2x10

2x

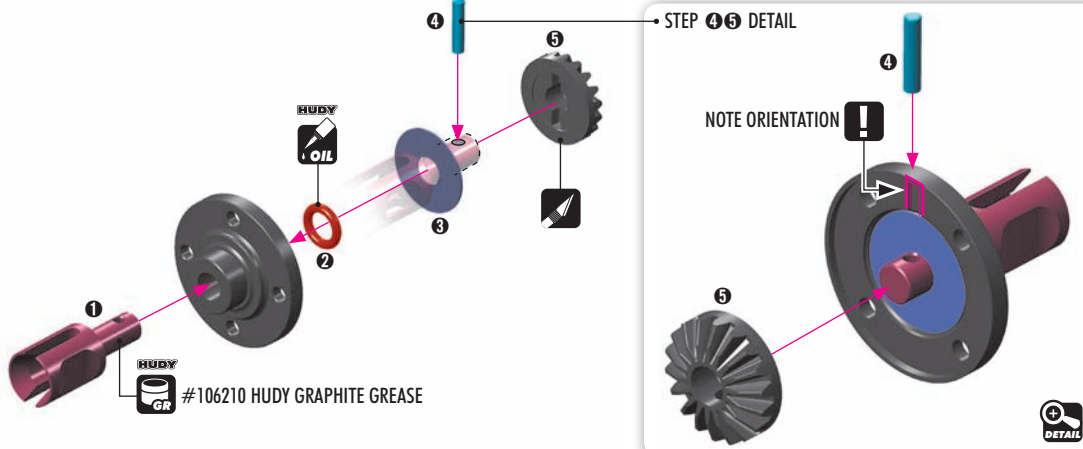

964050
S 5x15x0.3



971050
O 5x1.5



981210
P 2x10

2x

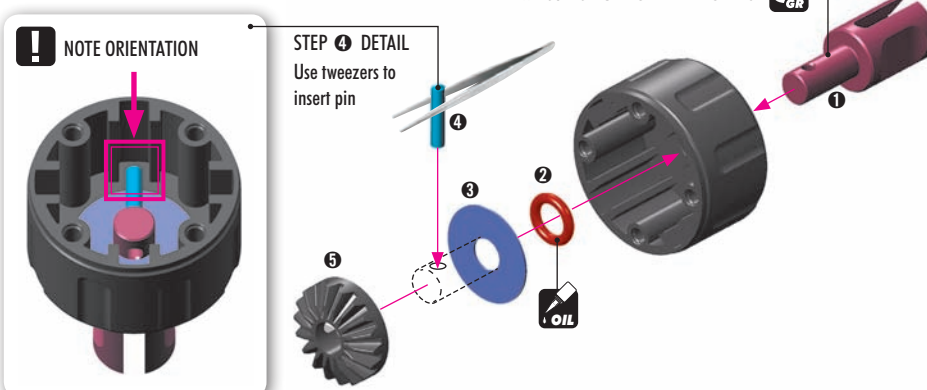

1. FRONT & REAR DIFFERENTIAL



964031
S 3.5x10x0.2

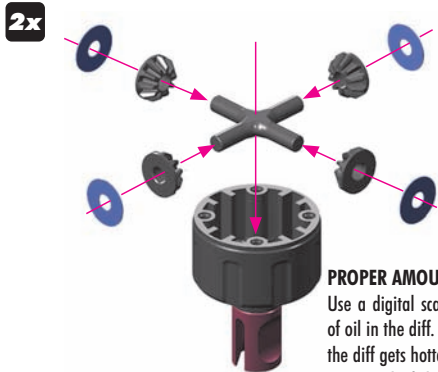

2x

Front diff

Silicone oil 10.000cSt
Fill just above the cross-pins.

Rear diff

Silicone oil 10.000cSt
Fill just above the cross-pins.

PROPER AMOUNT OF OIL IN THE DIFFS

Use a digital scale to measure the exact amount of oil in the diff. Remember that during operation the diff gets hotter and the heat may allow the oil to expand. If there is too much oil inside it may interfere with the diff operation and damage the internal gears.



Fill differential up to the top of the diff cross-pins. DO NOT fill the diff to the top of the housing.

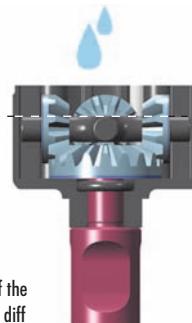

TO ENSURE YOU HAVE THE SAME AMOUNT OF OIL FROM REBUILD TO REBUILD, DO THE FOLLOWING:



1 Put the diff (without oil) on the scale and check the weight (approximately 11.47g)



2 Slowly pour oil into the diff and watch the weight. Add 1.83g of oil into the diff. The approximate weight of the diff including oil is 13.30g.

$$11.47g + 1.83g = 13.30g$$

#107865
HUDY Ultimate Digital Pocket Scale 300g±0.01g

TIP

FRONT DIFFERENTIAL

LOW TRACTION 7.000cSt (HUDY #106470)
MEDIUM-HIGH TRACTION 10.000cSt (HUDY #106510)
SUPER-HIGH TRACTION 15.000cSt (HUDY #106515)

NOTE:

Softer oil increases steering, harder oil increases stability.

TIPS FOR DIFFERENTIALS

REAR DIFFERENTIAL

LOW TRACTION 7.000cSt (HUDY #106470)
MEDIUM-HIGH TRACTION 10.000cSt (HUDY #106510)
SUPER-HIGH TRACTION 15.000cSt (HUDY #106515)

NOTE:

Softer oil increases rear traction, harder oil increases on-power steering.

TIP

SET-UP BOOK

DIFFERENTIAL OIL



903258
SFH M2.5x8



941014
BB 10x15x4

2x

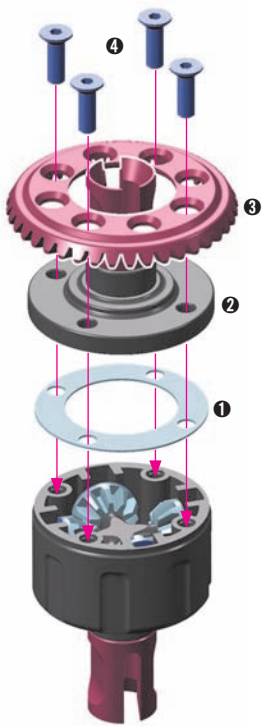

2x

Tighten the screws equally but do NOT tighten them completely.

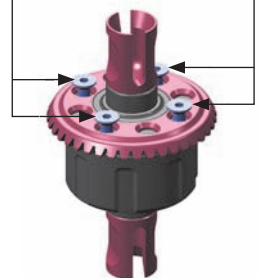

Finish tightening in this order.

2x

Use HUDY Ball-Bearing Grease

HUDY #106220 - STANDARD
GR #106221 - BLUE
GR #106222 - RED

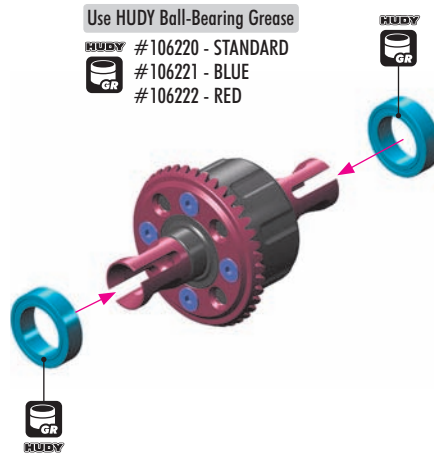

2. REAR CENTRAL TRANSMISSION

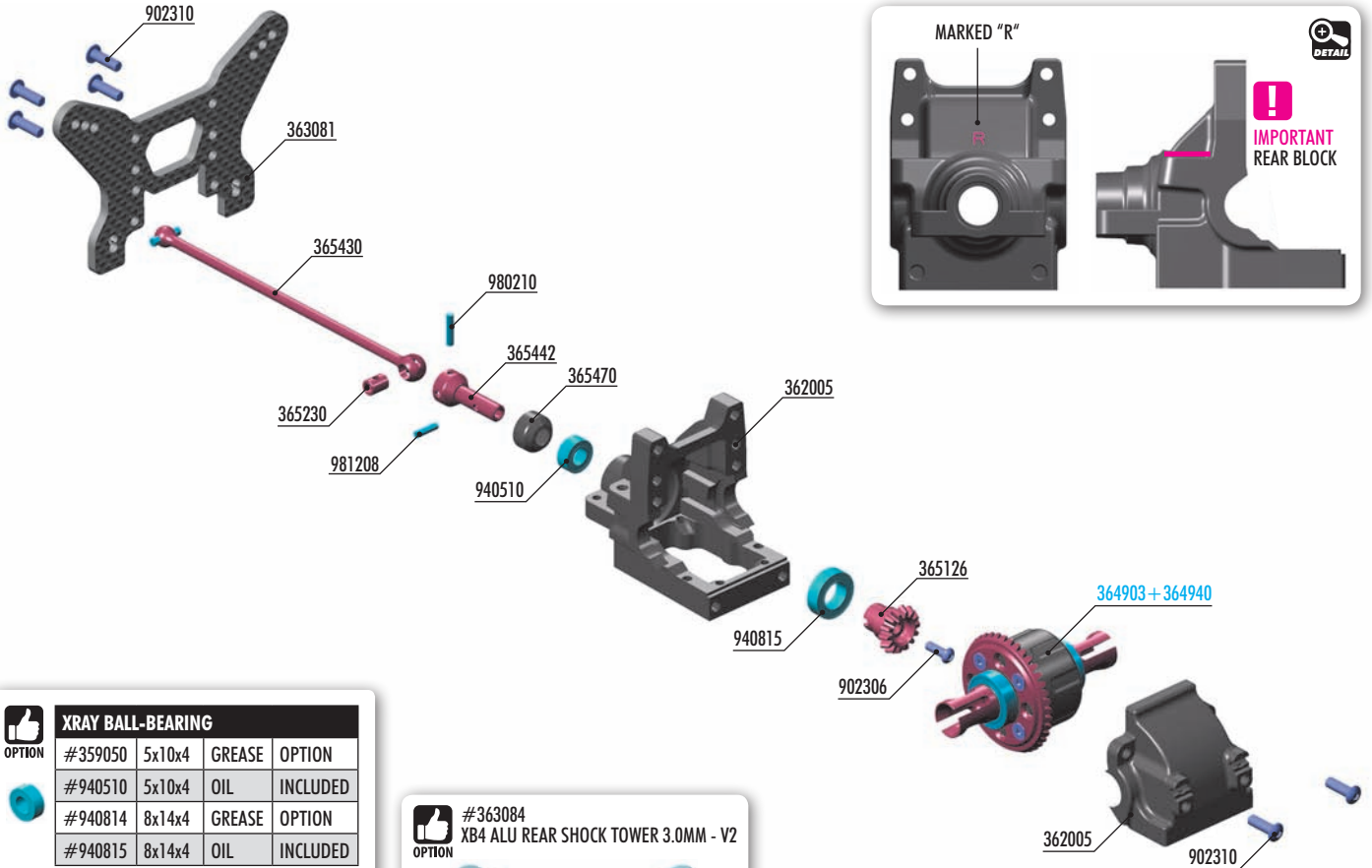

XRAY BALL-BEARING			
OPTION	#359050	5x10x4	GREASE
	#940510	5x10x4	OIL
	#940814	8x14x4	GREASE
	#940815	8x14x4	OIL

DRIVE SHAFT COLLAR		
OPTION	#365470	COMPOSITE
	#365471-K	ALU - BLACK
	#365471-O	ALU - ORANGE



BAG

02

- 362005 DIFF BULKHEAD BLOCK SET REAR - NARROW
- 363081 GRAPHITE SHOCK TOWER REAR 3.0MM - V2
- 365126 STEEL BEVEL DRIVE GEAR - CNC-MACHINED - 16T
- 365230 DRIVE SHAFT COUPLING - HUDY SPRING STEEL™
- 365430 CENTRAL DRIVE SHAFT 108MM WITH 2.5MM PIN - HUDY SPRING STEEL™
- 365442 CENTRAL SHAFT UNIVERSAL JOINT
- 365470 COMPOSITE DRIVE SHAFT SAFETY COLLAR - V2 (3)

- 902306 HEX SCREW SH M3x6 (10)
- 902310 HEX SCREW SH M3x10 (10)
- 940510 BALL-BEARING 5x10x4 RUBBER SEALED - OIL (2)
- 940815 BALL-BEARING 8x14x4 RUBBER SEALED - OIL (2)
- 980210 PIN 2x10 (10)
- 981208 PIN 2x8 (10)
- 364903 GEAR DIFFERENTIAL - LARGE VOLUME - SET
- 364940 STEEL DIFFERENTIAL BEVEL GEAR FOR LARGE VOLUME DIFF 40T

980210
P 2x10

! **DRIVE SHAFT COVER CAPS**
Lubricate the drive shaft connecting joint properly so the drive shaft turns freely. In the event that not enough grease is used, the connecting pin may lock and may even, in extreme situations, push through the drive shaft cover cap.

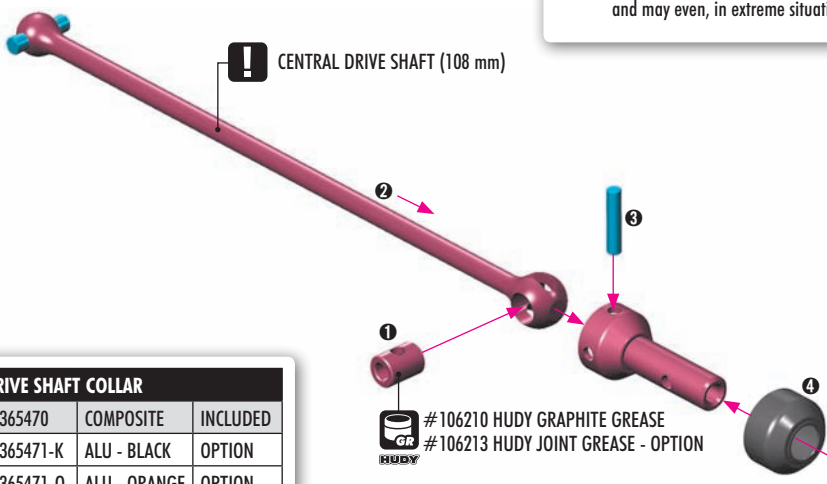

DRIVE SHAFT COLLAR		
OPTION	#365470	COMPOSITE
	#365471-K	ALU - BLACK
	#365471-O	ALU - ORANGE

- #106210 HUDY GRAPHITE GREASE
- #106213 HUDY JOINT GREASE - OPTION

2. REAR CENTRAL TRANSMISSION

902306
SH M3x6

940510
BB 5x10x4

940815
BB 8x14x4

981208
P 2x8

Bearing with BLUE rubber covers

Bearing Oil (HUDY #106230)

5x10x4mm

5x10x4mm

5x10x4mm

5x10x4mm

Bearing Oil (HUDY #106230)

8x14x4mm

THREAD LOCK

GRAPHITE GREASE (HUDY #106210)

IMPORTANT REAR BLOCK

XRAY BALL-BEARING			
OPTION			
#359050	5x10x4	GREASE	OPTION
#940510	5x10x4	OIL	INCLUDED
#940814	8x14x4	GREASE	OPTION
#940815	8x14x4	OIL	INCLUDED

902310
SH M3x10

FRONT

REAR

REAR DIFF 10.000 c/s

IMPORTANT

Cut the edge on both sides

902310
SH M3x10

ALTERNATIVE 1
Rear shock tower mounted from the **FRONT**

INITIAL SETTING

Follow the **TECH TIP** on page 5 to prepare graphite parts

TIP

REAR

FRONT

#363084
XB4 ALU REAR SHOCK TOWER 3.0MM - V2

OPTION

ALTERNATIVE 2
Rear shock tower mounted from the **REAR**

REAR

FRONT

2. FRONT CENTRAL TRANSMISSION

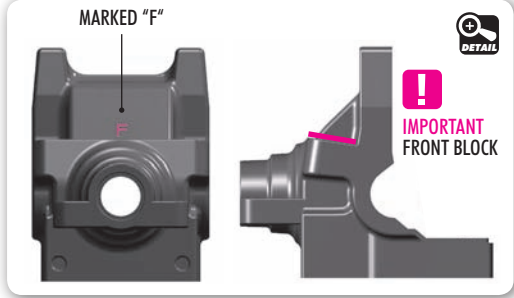
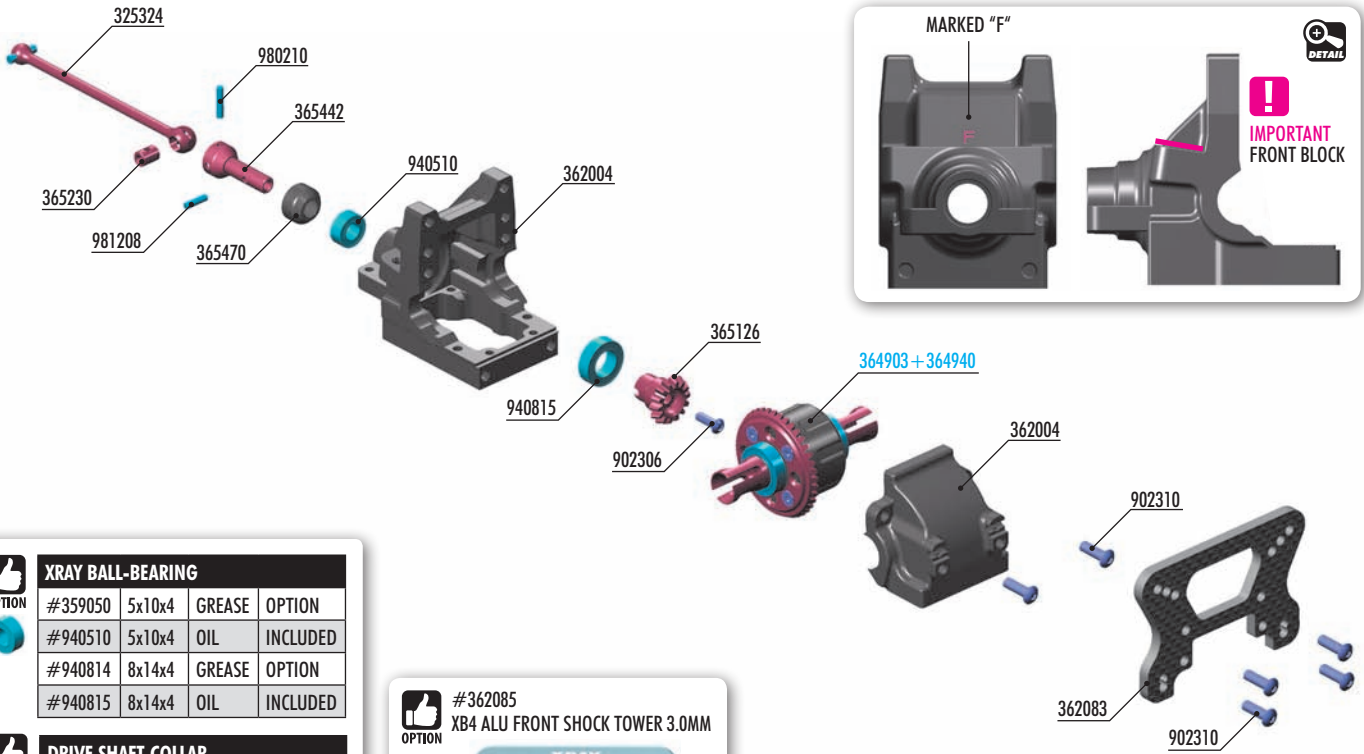

XRAY BALL-BEARING				
OPTION	#359050	5x10x4	GREASE	OPTION
	#940510	5x10x4	OIL	INCLUDED
	#940814	8x14x4	GREASE	OPTION
	#940815	8x14x4	OIL	INCLUDED

DRIVE SHAFT COLLAR		
OPTION	#365470	COMPOSITE INCLUDED
	#365471-K	ALU - BLACK OPTION
	#365471-O	ALU - ORANGE OPTION



- 325324 DRIVE SHAFT 75MM WITH 2.5MM PIN - HUDY SPRING STEEL™
- 362004 DIFF BULKHEAD BLOCK SET FRONT - NARROW
- 362083 GRAPHITE SHOCK TOWER FRONT 3.5MM
- 365126 STEEL BEVEL DRIVE GEAR - CNC-MACHINED - 16T
- 365230 DRIVE SHAFT COUPLING - HUDY SPRING STEEL™
- 365442 CENTRAL SHAFT UNIVERSAL JOINT
- 365470 COMPOSITE DRIVE SHAFT SAFETY COLLAR - V2 (3)
- 902306 HEX SCREW SH M3x6 (10)

- 902310 HEX SCREW SH M3x10 (10)
- 940510 BALL-BEARING 5x10x4 RUBBER SEALED - OIL (2)
- 940815 BALL-BEARING 8x14x4 RUBBER SEALED - OIL (2)
- 980210 PIN 2x10 (10)
- 981208 PIN 2x8 (10)
- 364903 GEAR DIFFERENTIAL - LARGE VOLUME - SET
- 364940 STEEL DIFFERENTIAL BEVEL GEAR FOR LARGE VOLUME DIFF 40T

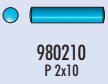

! DRIVE SHAFT COVER CAPS
Lubricate the drive shaft connecting joint properly so the drive shaft turns freely. In the event that not enough grease is used, the connecting pin may lock and may even, in extreme situations, push through the drive shaft cover cap.

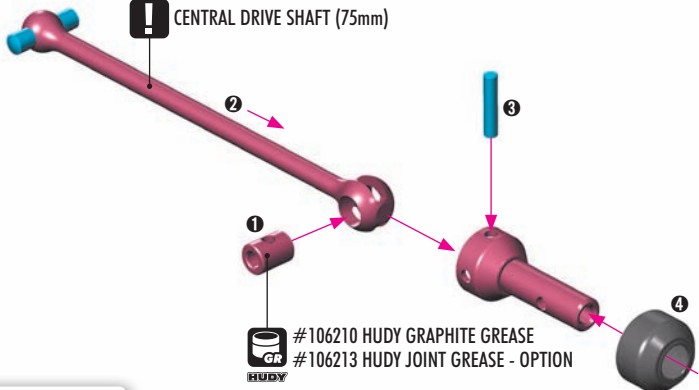

DRIVE SHAFT COLLAR		
OPTION	#365470	COMPOSITE INCLUDED
	#365471-K	ALU - BLACK OPTION
	#365471-O	ALU - ORANGE OPTION

#106210 HUDY GRAPHITE GREASE
#106213 HUDY JOINT GREASE - OPTION

2. FRONT CENTRAL TRANSMISSION

902306
SH M3x6

940510
BB 5x10x4

940815
BB 8x14x4

981208
P 2x8

Bearing with BLUE rubber covers

Bearing Oil (HUDY #106230)

5x10x4mm

Bearing Oil (HUDY #106230)

8x14x4mm

THREAD LOCK

GRAPHITE GREASE (HUDY #106210)

IMPORTANT FRONT BLOCK

XRAY BALL-BEARING			
OPTION			
#359050	5x10x4	GREASE	OPTION
#940510	5x10x4	OIL	INCLUDED
#940814	8x14x4	GREASE	OPTION
#940815	8x14x4	OIL	INCLUDED

902310
SH M3x10

REAR

NOTE ORIENTATION

FRONT DIFF 10.000 c/s

FRONT

902310
SH M3x10

REAR

NOTE ORIENTATION

Follow the TECH TIP on page 5 to prepare graphite parts

TIP

FRONT

#362085
XB4 ALU FRONT SHOCK TOWER 3.0MM

3. REAR SUSPENSION

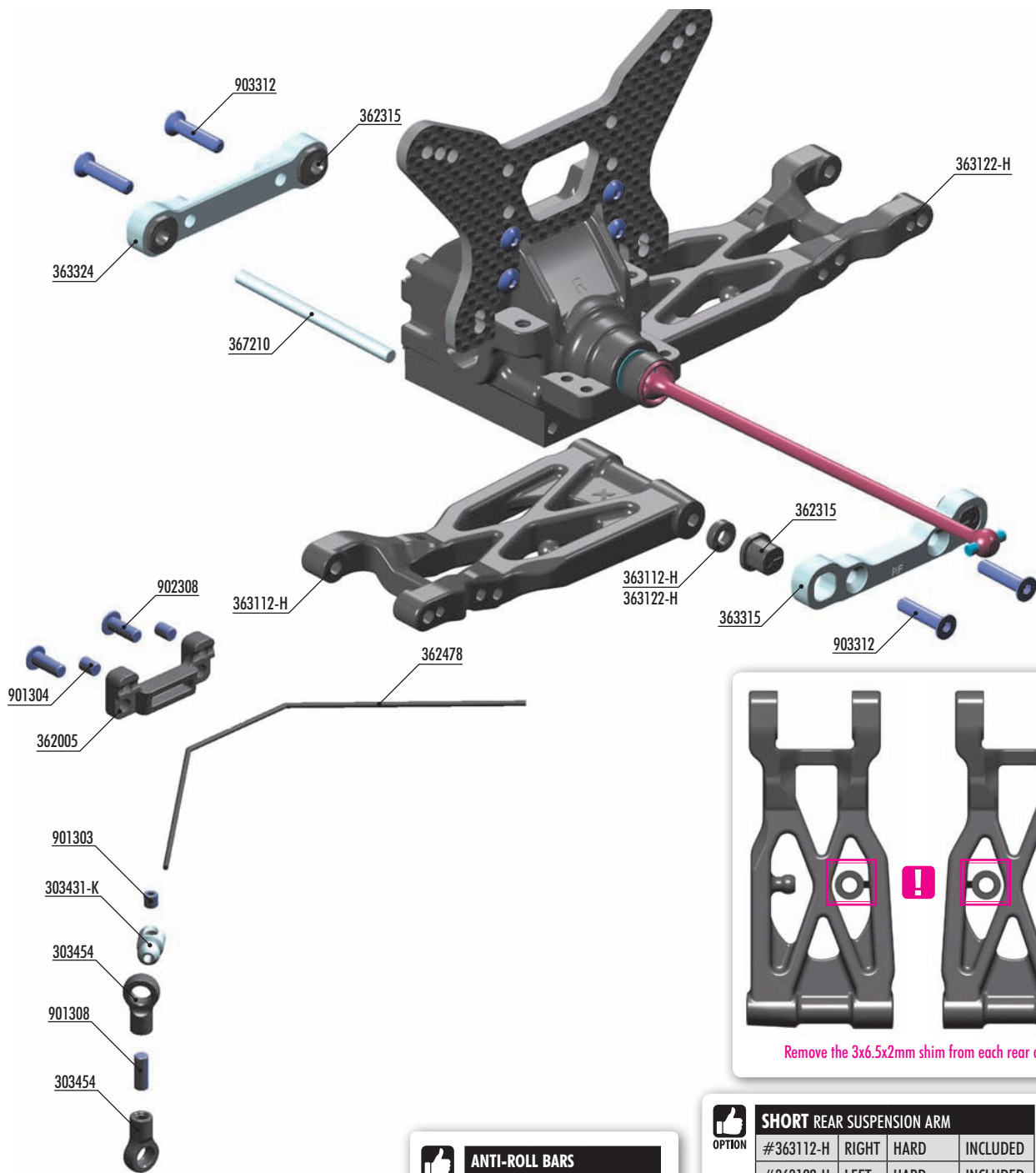

OPTION #363314
 ALU LOWER SUSP. HOLDER 3° REAR-FRONT NARROW - 7075 T6

3°
1-DOT

OPTION

ANTI-ROLL BARS			
#362470	1.0mm	OPTION	
#362471	1.1mm	OPTION	
#362472	1.2mm	OPTION	
#362473	1.3mm	OPTION	
#362474	1.4mm	OPTION	
#362476	1.6mm	OPTION	
#362478	1.8mm	INCLUDED	
#362480	2.0mm	OPTION	

OPTION

SHORT REAR SUSPENSION ARM			
#363112-H	RIGHT	HARD	INCLUDED
#363122-H	LEFT	HARD	INCLUDED
#363112-G	RIGHT	GRAPHITE	OPTION
#363122-G	LEFT	GRAPHITE	OPTION

OPTION

LONG REAR SUSPENSION ARM			
#363113-H	RIGHT	HARD	OPTION
#363123-H	LEFT	HARD	OPTION
#363113-G	RIGHT	GRAPHITE	OPTION
#363123-G	LEFT	GRAPHITE	OPTION



- 303431-K ALU 4.9MM BALL END - BLACK (2)
- 303454 BALL JOINT 4.9MM - OPEN (4)
- 362005 DIFF BULKHEAD BLOCK SET REAR - NARROW
- 362315 ECCENTRIC BUSHING SET (2)
- 362478 ANTI-ROLL BAR 1.8 MM
- 363112-H COMPOSITE SUSPENSION ARM REAR LOWER RIGHT - HARD
- 363122-H COMPOSITE SUSPENSION ARM REAR LOWER LEFT - HARD
- 363315 ALU LOWER SUSP. HOLDER 1° REAR-FRONT - NARROW - 7075 T6
- 363324 ALU LOWER SUSP. HOLDER REAR-REAR - NARROW - 7075 T6
- 367210 SUSPENSION PIVOT PIN (2)

- 901303 HEX SCREW SB M3x3 (10)
- 901304 HEX SCREW SB M3x4 (10)
- 901308 HEX SCREW SB M3x8 (10)
- 902308 HEX SCREW SH M3x8 (10)
- 903312 HEX SCREW SFH M3x12 (10)

3. REAR SUSPENSION

IO
From Rear Arm SHIM 3x6.5x2
903312 SFH M3x12

IMPORTANT REAR BLOCK

#363314 ALU LOWER SUSP. HOLDER 3° REAR-FRONT NARROW - 7075 T6
3° 1-DOT

Composite eccentric bushings
INITIAL SETTING

TIP
If the suspension arm does not move freely use a HUDY Arm Reamer to size the holes of the arms.
Arm Reamer 3.0mm (HUDY #107633)

Marked "L"
LEFT
RR 1°
Marked "R"
RIGHT
2mm from rear arm
2mm from rear arm
RF
FRONT
Composite eccentric bushings
INITIAL SETTING

For SHORT arms use only OUTER positions.

For SHORT arms do not use INNER positions.

SHORT REAR SUSPENSION ARM			
#363112-H	RIGHT	HARD	INCLUDED
#363122-H	LEFT	HARD	INCLUDED
#363112-G	RIGHT	GRAPHITE	OPTION
#363122-G	LEFT	GRAPHITE	OPTION

For LONG arms use only INNER positions.

For LONG arms do not use OUTER positions.

LONG REAR SUSPENSION ARM			
#363113-H	RIGHT	HARD	OPTION
#363123-H	LEFT	HARD	OPTION
#363113-G	RIGHT	GRAPHITE	OPTION
#363123-G	LEFT	GRAPHITE	OPTION



SET-UP BOOK
TOE-IN
ANTI-SQUAT
ROLL CENTER
TRACK-WIDTH

ECCENTRIC BUSHINGS HAVE TWO DIFFERENT OFFSETS FROM THE CENTER.



The XRAY rear alu lower suspension holders provide great range of adjustment for the rear suspension. Using different combinations of eccentric bushings, fine adjustment of rear anti-squat, rear toe-in, rear roll center, and rear track-width can be obtained. For more information about the influence of rear anti-squat, rear toe-in, rear roll center and rear track width on car handling, please refer to HUDY Set-up Book (#209100).

ANTI-SQUAT			(°)
RR	RF		
○	○	○	= 2°
○	○	○	= 3°
○	○	○	= 1°
○	○	○	= 3°
○	○	○	= 2°
○	○	○	= 4°
○	○	○	= 1°
○	○	○	= 2°
○	○	○	= 0°

ROLL CENTER			(mm)
RR	RF		
○	○	○	= +0.75mm
○	○	○	= 0mm
○	○	○	= -0.75mm

TRACK-WIDTH			(mm)
RR	RF		
○	○	○	= +1.5mm
○	○	○	= 0mm
○	○	○	= -1.5mm

TOE-IN			(°)
RR	RF		
○	○	○	= 1°
○	○	○	= 2°
○	○	○	= 0°
○	○	○	= 2°
○	○	○	= 1°
○	○	○	= -1°
○	○	○	= 2°
○	○	○	= 3°
○	○	○	= 1°

The track-width is directly influenced by the size of the wheels and tires used.

The tables describe the amounts of adjustment using the center and outside positions of the eccentric bushings. The middle position eccentric bushings allow for finer adjustment increments.

3. REAR SUSPENSION



901308
SB M3x8

2x
L=R

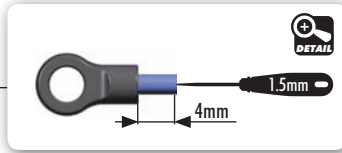
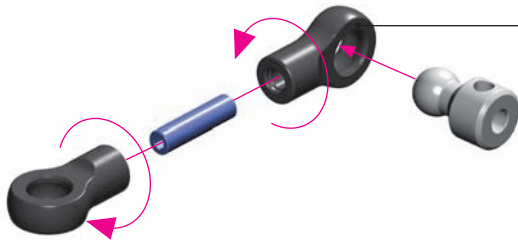

901303
SB M3x3



901304
SB M3x4

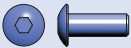

902308
SH M3x8



ANTI-ROLL BARS

OPTION

#362470	1.0mm	OPTION
#362471	1.1mm	OPTION
#362472	1.2mm	OPTION
#362473	1.3mm	OPTION
#362474	1.4mm	OPTION
#362476	1.6mm	OPTION
#362478	1.8mm	INCLUDED
#362480	2.0mm	OPTION

FRONT

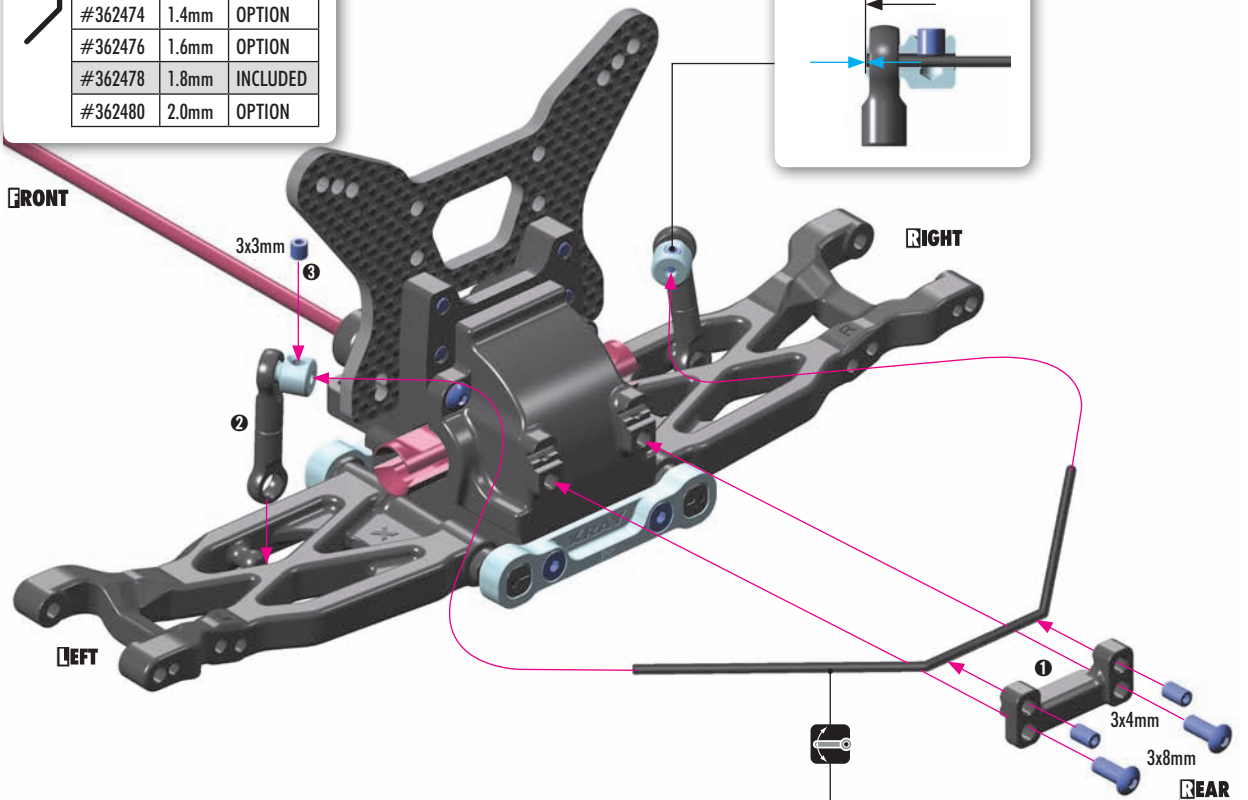

STEP 3 DETAIL

L=R

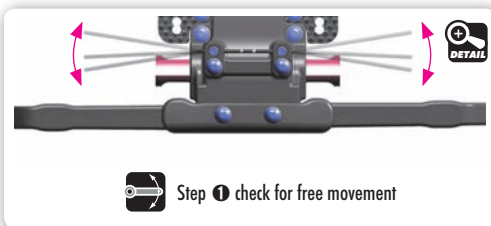
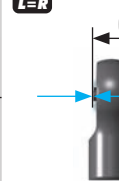

Step 1 check for free movement

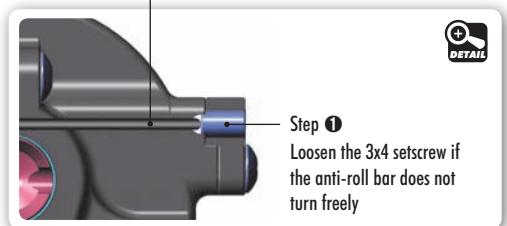

Step 1
Loosen the 3x4 setscrew if
the anti-roll bar does not
turn freely

SET-UP
BOOK

ANTI-ROLL BAR

3. FRONT SUSPENSION

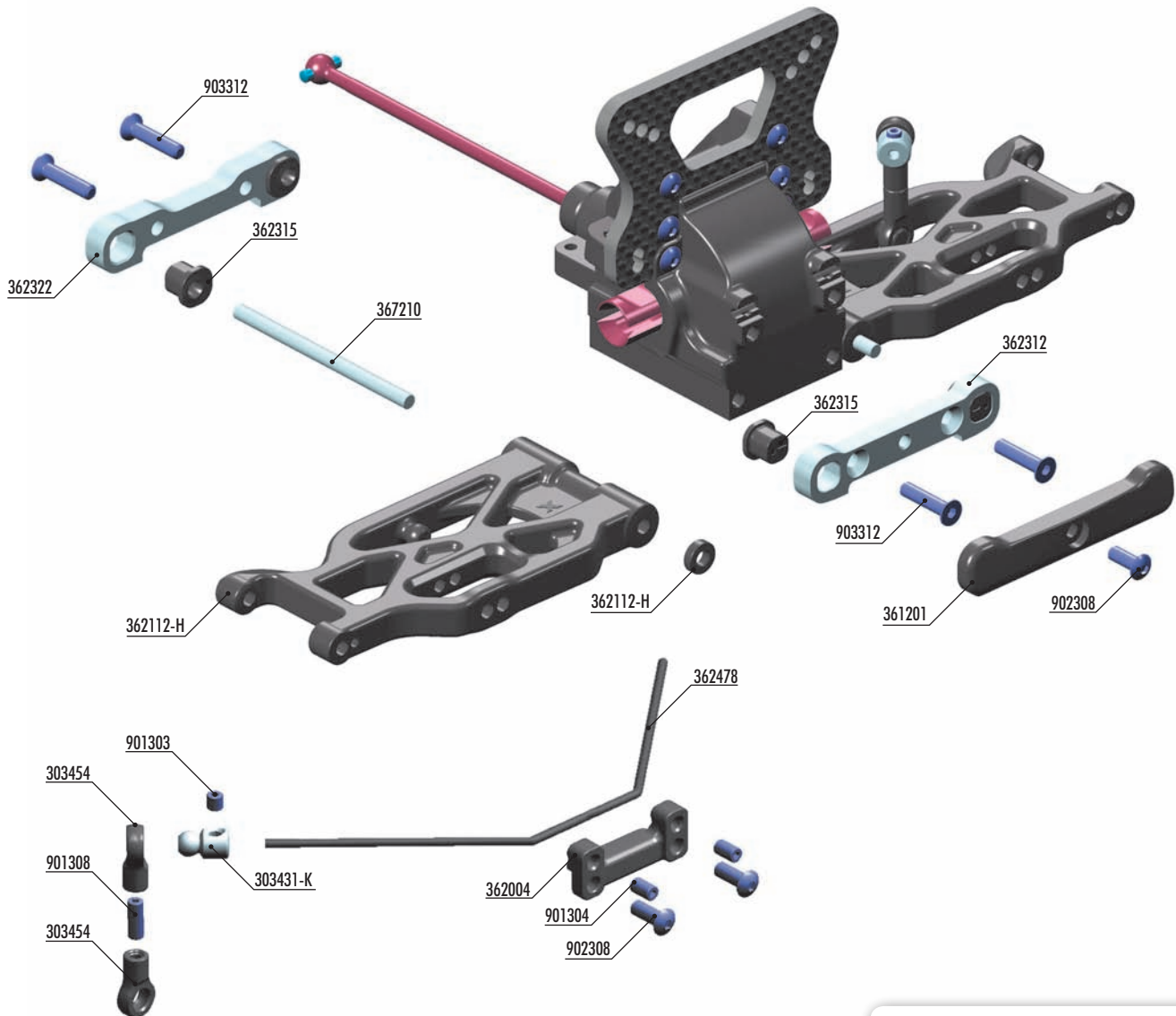

Remove the 3x6.5x2mm shim from each front arm.

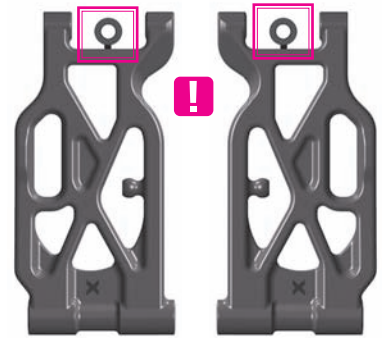

ANTI-ROLL BARS			
#362470	1.0mm	OPTION	
#362471	1.1mm	OPTION	
#362472	1.2mm	OPTION	
#362473	1.3mm	OPTION	
#362474	1.4mm	OPTION	
#362476	1.6mm	OPTION	
#362478	1.8mm	INCLUDED	
#362480	2.0mm	OPTION	

SHORT FRONT SUSPENSION ARM			
#362112	MEDIUM	OPTION	
#362112-H	HARD	INCLUDED	
#362112-G	GRAPHITE	OPTION	

LONG FRONT SUSPENSION ARM			
#362113-H	HARD	OPTION	
#362113-G	GRAPHITE	OPTION	

BAG
03

- | | | | |
|----------|---|--------|--------------------------|
| 303431-K | ALU 4.9MM BALL END - BLACK (2) | 901303 | HEX SCREW SB M3x3 (10) |
| 303454 | BALL JOINT 4.9MM - OPEN (4) | 901304 | HEX SCREW SB M3x4 (10) |
| 361201 | COMPOSITE FRONT BUMPER - ONE HOLE | 901308 | HEX SCREW SB M3x8 (10) |
| 362004 | DIFF BULKHEAD BLOCK SET FRONT - NARROW | 902308 | HEX SCREW SH M3x8 (10) |
| 362112-H | COMPOSITE SUSPENSION ARM FRONT LOWER - HARD | 903312 | HEX SCREW SFH M3x12 (10) |
| 362312 | ALU LOWER SUSP. HOLDER FRONT-FRONT - NARROW - 7075 T6 | | |
| 362315 | ECCENTRIC BUSHING SET (2) | | |
| 362322 | ALU LOWER SUSP. HOLDER FRONT-REAR - NARROW - 7075 T6 | | |
| 362478 | ANTI-ROLL BAR 1.8 MM | | |
| 367210 | SUSPENSION PIVOT PIN (2) | | |

3. FRONT SUSPENSION

10
From Front Arm
SHIM 3x6.5x2



903312
SFH M3x12

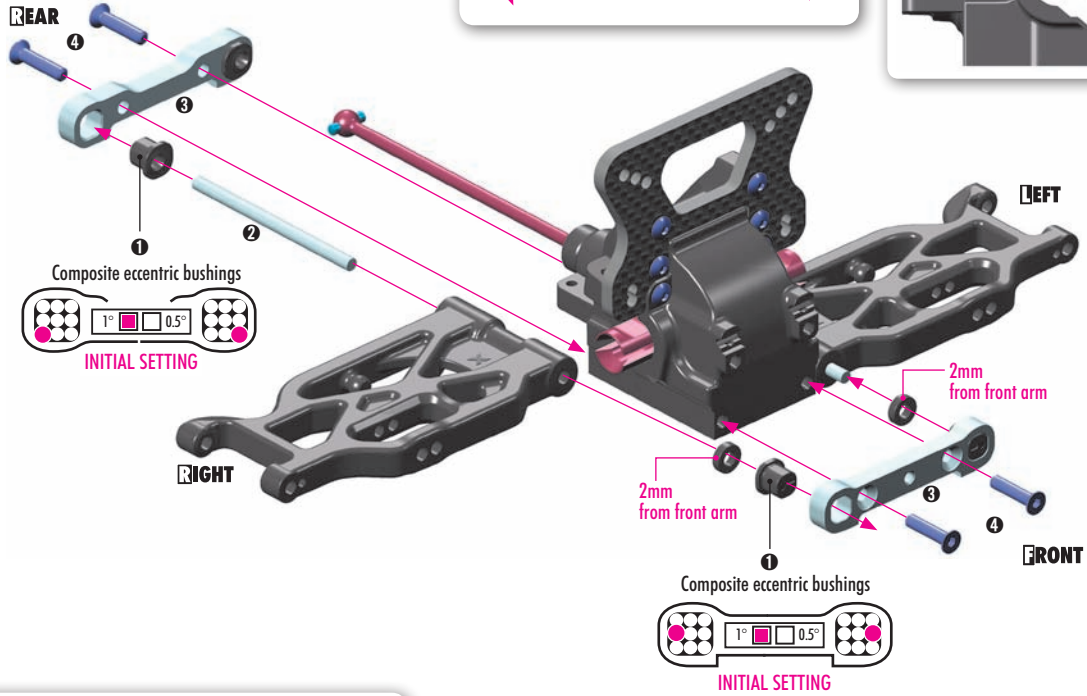

TIP If the suspension arm does not move freely use a HUDY Arm Reamer to size the holes of the arms

Arm Reamer 3.0mm (HUDY #107633)

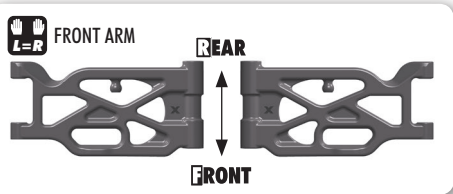

✓ For SHORT arms use only OUTER positions. **OPTION**

SHORT FRONT SUSPENSION ARM			
#362112	MEDIUM	OPTION	
#362112-H	HARD	INCLUDED	
#362112-G	GRAPHITE	OPTION	

✗ For SHORT arms do not use INNER positions.

✓ For LONG arms use only INNER positions. **OPTION**

LONG FRONT SUSPENSION ARM			
#362113-H	HARD	OPTION	
#362113-G	GRAPHITE	OPTION	

✗ For LONG arms do not use OUTER positions.

SET-UP BOOK
KICK UP
ROLL CENTER
TRACK-WIDTH

ECCENTRIC BUSHINGS HAVE TWO DIFFERENT OFFSETS FROM THE CENTER.



The XRAY alu front lower suspension holders provide great range of adjustment for the front suspension. Using different combinations of eccentric bushings, fine adjustment of front kick-up, roll-center, and front track-width can be obtained. For more information about the influence of kick-up, front track-width, and roll centers on car handling, please refer to HUDY Set-up Book (#209100).

KICK-UP		
FF	FR	(°)
		= 7°
		= 6°
		= 8°
		= 6°
		= 5°
		= 7°
		= 8°
		= 7°
		= 9°

ROLL CENTER		
FF	FR	(mm)
		= +0.75mm
		= 0mm
		= -0.75mm

TRACK-WIDTH		
FF	FR	(mm)
		= +1.5mm
		= 0mm
		= -1.5mm

The tables describe the amounts of adjustment using the center and outside positions of the eccentric bushings. The middle position eccentric bushings allow for finer adjustment increments.

The track-width is directly influenced by the size of the wheels and tires used.

TOTAL CASTER=C-HUB CASTER+KICK UP						
C-HUB CASTER	KICK-UP					
	6°	7°	8°	9°	10°	
	6°	12°	13°	14°	15°	16°
9°	15°	16°	17°	18°	19°	

Caster is the angle between the steering pivot axis and the vertical plane. Caster is affected not only by the C-Hub caster, but also by the front kick-up angle relative to the flat chassis bottom. The table indicates how kick up angle effects total caster.

The XB4's stock caster blocks are 9°, but 6° blocks are available as an option.

3. FRONT SUSPENSION



901308
SB M3x8

2x
L=R

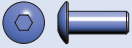
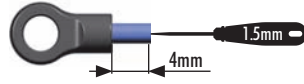
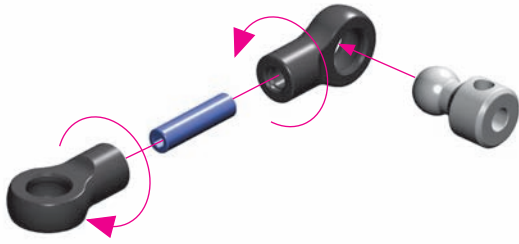

902308
SH M3x8

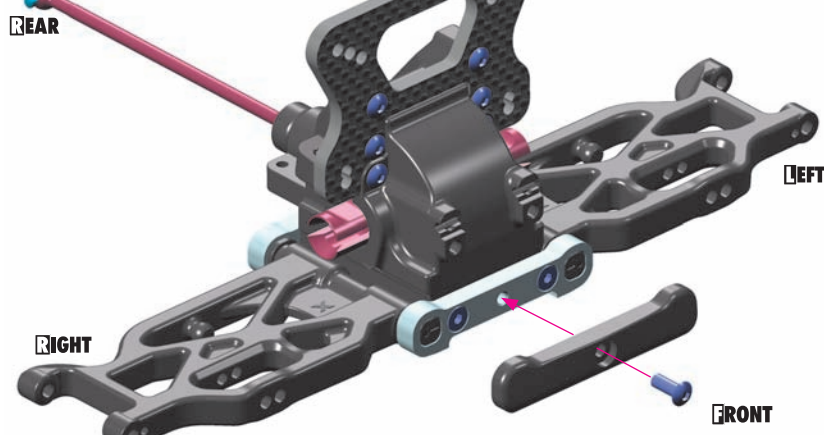

901303
SB M3x3



901304
SB M3x4



902308
SH M3x8

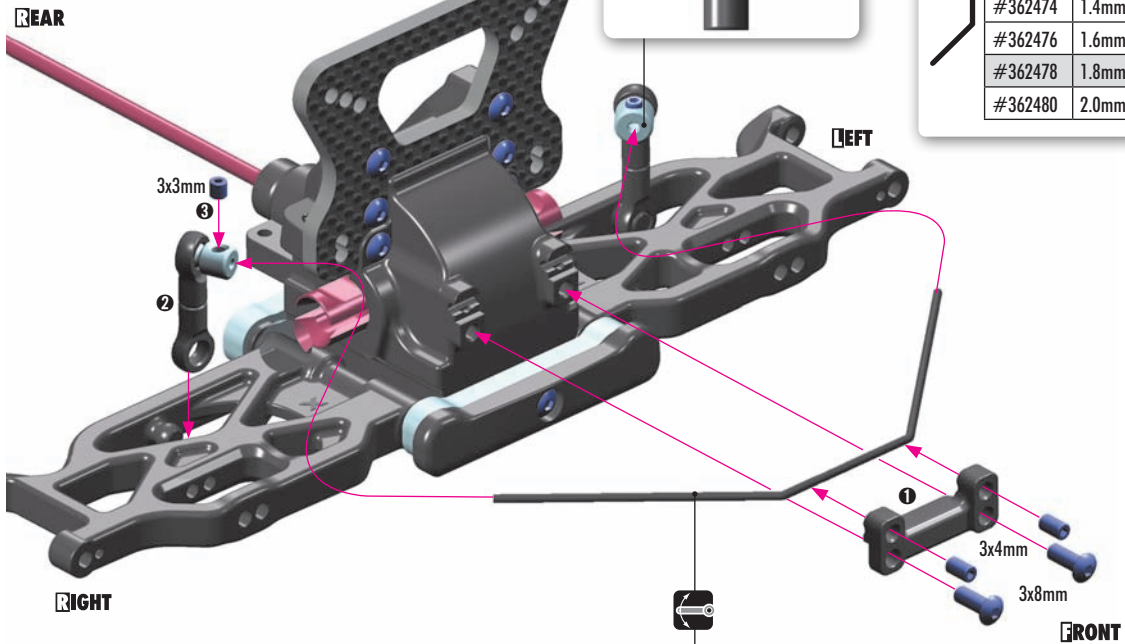

STEP 1 DETAIL

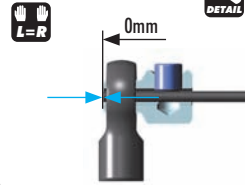

ANTI-ROLL BARS

OPTION	ANTI-ROLL BARS		
#362470	1.0mm	OPTION	
#362471	1.1mm	OPTION	
#362472	1.2mm	OPTION	
#362473	1.3mm	OPTION	
#362474	1.4mm	OPTION	
#362476	1.6mm	OPTION	
#362478	1.8mm	INCLUDED	
#362480	2.0mm	OPTION	

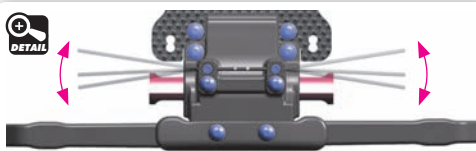

Step 1 check for free movement

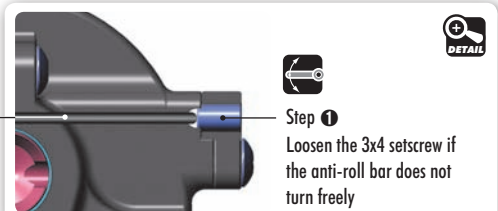

Step 1
Loosen the 3x4 setscrew if the anti-roll bar does not turn freely

SET-UP BOOK

ANTI-ROLL BAR

4. REAR TRANSMISSION

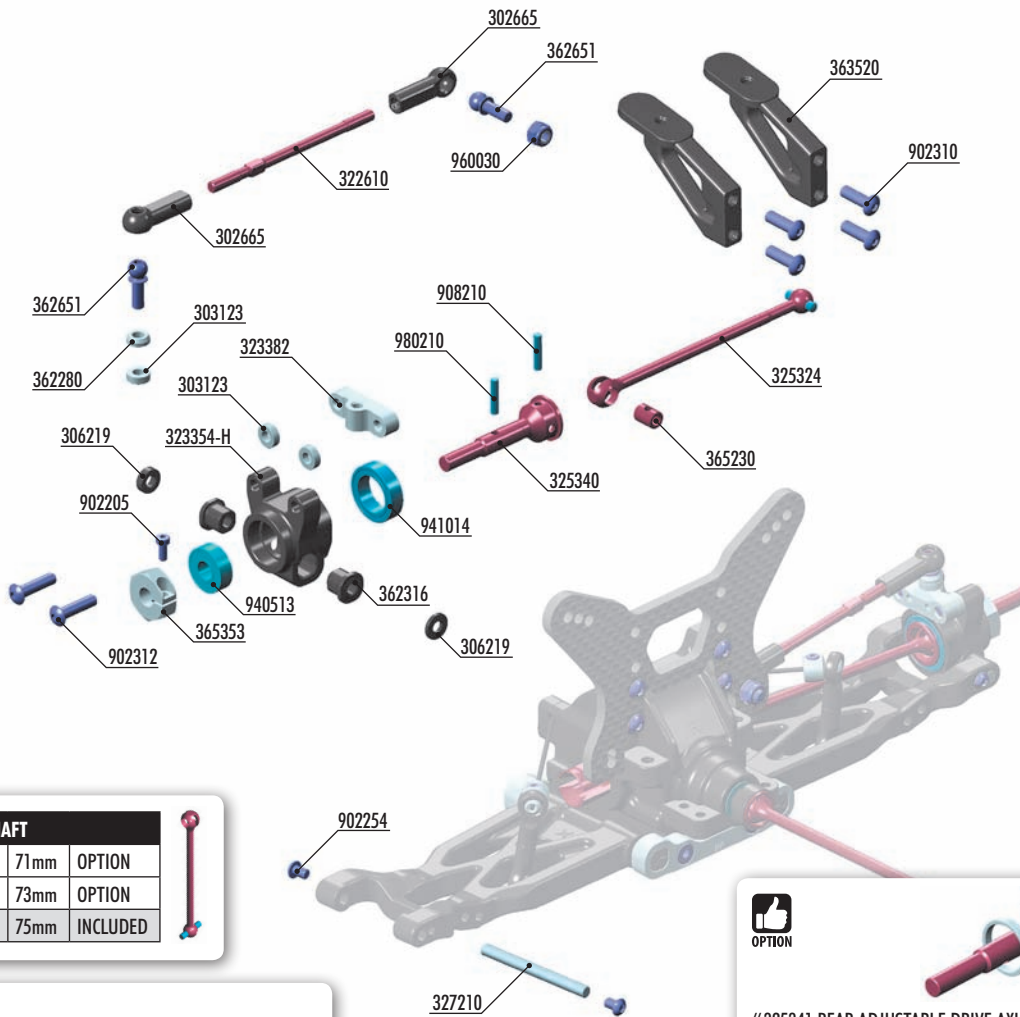

DRIVE SHAFT

#325323	71mm	OPTION
#325326	73mm	OPTION
#325324	75mm	INCLUDED



#323381
ALU REAR HUB PLATE FOR MULTI ADJUSTABLE UPRIGHT
- SWISS 7075 T6



XRAY BALL-BEARING

#940512	5x12x4	OIL	OPTION
#941015	10x15x4	OIL	OPTION
#940513	5x12x4	GREASE	INCLUDED
#941014	10x15x4	GREASE	INCLUDED



ALU CONICAL SHIM

#362280	SILVER	INCLUDED
#362280-K	BLACK	OPTION
#362280-O	ORANGE	OPTION



REAR UPRIGHTS

#323354-H	COMPOSITE - H	INCLUDED
#323354-G	COMPOSITE - G	OPTION
#323355	ALU	OPTION



ALU NUTS M3

#296530-B	BLUE	OPTION
#296530-K	BLACK	OPTION
#296530-O	ORANGE	OPTION
#960031	SILVER	INCLUDED



#325341 REAR ADJUSTABLE DRIVE AXLE LB - HUDY SPRING STEEL™
#325390 ALU SHIM 10x12x2MM (2)



WHEEL HUBS 12MM

#365360	+4.5mm - (6 slots)	OPTION
#365359	+3.75mm (5 slots)	OPTION
#365358	+3.0mm (4 slots)	OPTION
#365357	+2.25mm (3 slots)	OPTION
#365356	+1.5mm (2 slots)	OPTION
#365355	+0.75mm (1 slot)	OPTION
#365353	0mm (0 slots)	INCLUDED
#365354	-0.75mm (Lightw.)	OPTION
#365361	-1.25mm (Lightw.)	OPTION



WHEEL HUBS 14MM

#365352	+0.75mm	OPTION
#365350	0mm	OPTION
#365351	-0.75mm	OPTION



BAG

04

302665 COMPOSITE BALL JOINT 4.9MM - CLOSED WITH HOLE (4)
303123 ALU SHIM 3x6x2.0MM (10)
306219 COMPOSITE SET OF SERVO SHIMS (4)
322610 ADJ. TURNBUCKLE M3 L/R 55 MM - SPRING STEEL (2)
323354-H COMPOSITE UPRIGHT REAR - HARD
323382 ALU REAR HUB PLATE FOR MULTI ADJ. UPRIGHT - 1-HOLE
325324 REAR DRIVE SHAFT 75MM WITH 2.5MM PIN - SPRING STEEL™
325340 REAR DRIVE AXLE LB - HUDY SPRING STEEL™
327210 FRONT SUSPENSION PIVOT PIN (2)
362280 ALU CONICAL SHIM 3x6x2.0MM (10)
362316 OPEN ECCENTRIC BUSHING SET (2)
362651 BALL END 4.9MM WITH THREAD 8MM (2)
363520 REAR WING POST - V2 (2)

365230 DRIVE SHAFT COUPLING - HUDY SPRING STEEL™
365353 ALU WHEEL HUB 12MM (2)
902205 HEX SCREW SH M2x5 (10)
902254 HEX SCREW SH M2.5x4 (10)
902310 HEX SCREW SH M3x10 (10)
902312 HEX SCREW SH M3x12 (10)
940513 BALL-BEARING 5x12x4 RUBBER SEALED - GREASE (2)
941014 BALL-BEARING 10x15x4 RUBBER SEALED - GREASE (2)
960030 NUT M3 (10)
980210 PIN 2x10 (10)

4. REAR TRANSMISSION

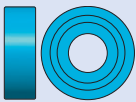

940513
BB 5x12x4



941014
BB 10x15x4



980210
P 2x10



902205
SH M2x5

2x L=R

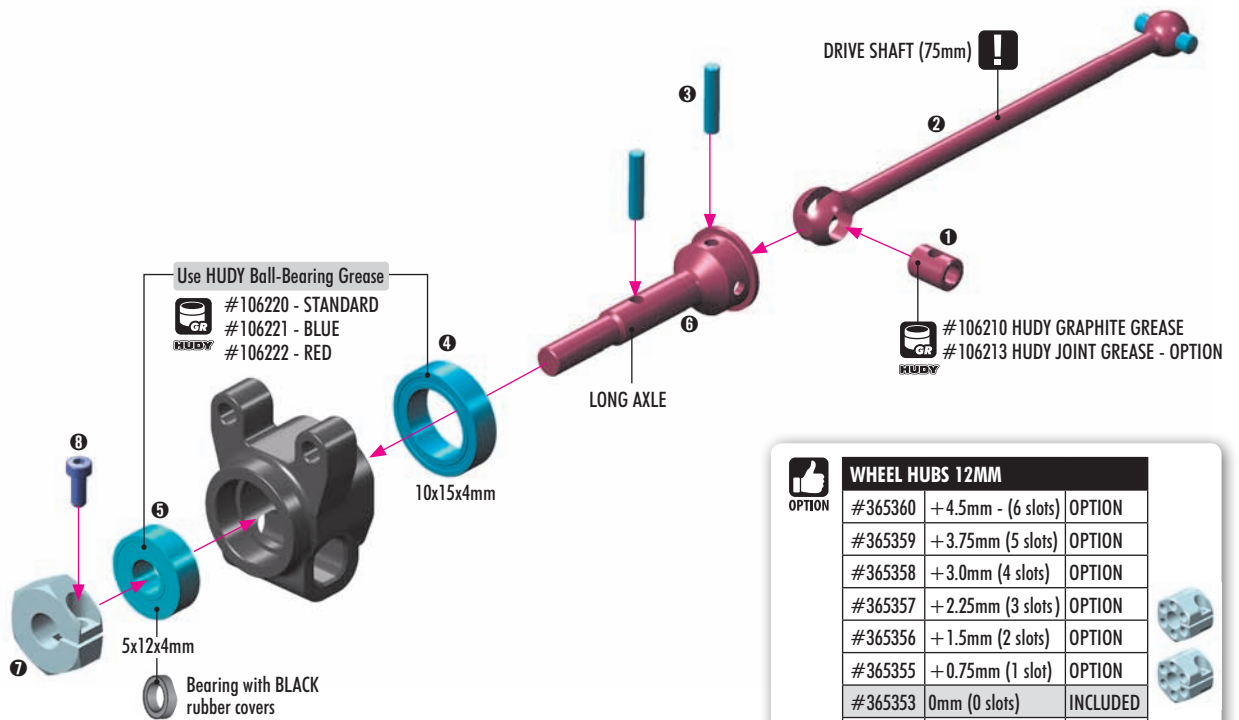

OPTION	DRIVE SHAFT		
	#325323	71mm	OPTION
	#325326	73mm	OPTION
	#325324	75mm	INCLUDED

OPTION	XRAY BALL-BEARING		
	#940512	5x12x4	OIL OPTION
	#941015	10x15x4	OIL OPTION
	#940513	5x12x4	GREASE INCLUDED
	#941014	10x15x4	GREASE INCLUDED

OPTION	WHEEL HUBS 12MM	
	#365360	+4.5mm - (6 slots) OPTION
	#365359	+3.75mm (5 slots) OPTION
	#365358	+3.0mm (4 slots) OPTION
	#365357	+2.25mm (3 slots) OPTION
	#365356	+1.5mm (2 slots) OPTION
	#365355	+0.75mm (1 slot) OPTION
	#365353	0mm (0 slots) INCLUDED
	#365354	-0.75mm (Lightw.) OPTION
	#365361	-1.25mm (Lightw.) OPTION

OPTION	WHEEL HUBS 14MM	
	#365352	+0.75mm OPTION
	#365350	0mm OPTION
	#365351	-0.75mm OPTION

OPTIONAL HEX HUB EFFECTS

Different offset hex hubs are used to increase or decrease the track-width.

LESS OFFSET **MORE OFFSET**
 Rear - more traction Rear - less traction
 Front - more steering Front - less steering

OPTION	REAR UPRIGHTS		
	#323354-H	HARD	INCLUDED
	#323354-G	GRAPHITE	OPTION
	#323355	ALU	OPTION



303123
SHIM 3x6x2



902312
SH M3x12

2x L=R

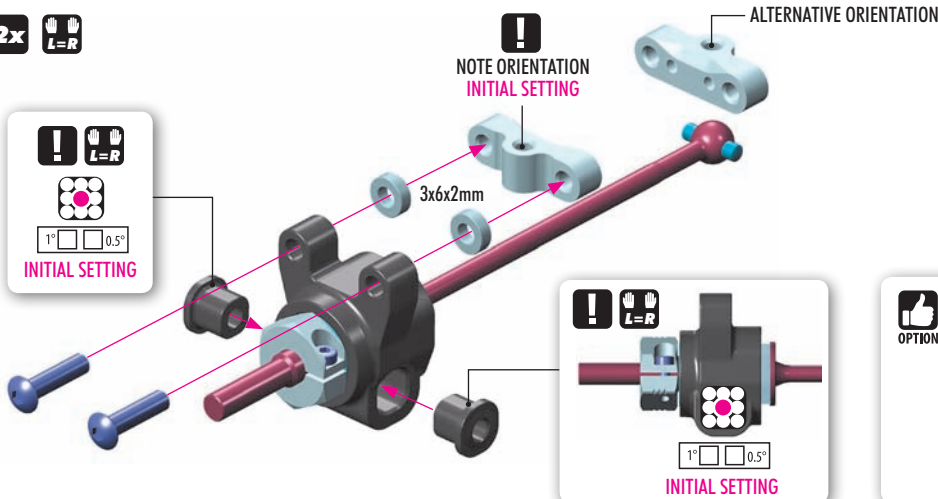

#323381
OPTION ALU REAR HUB PLATE FOR MULTI
ADJUSTABLE UPRIGHT - SWISS 7075 T6



4. REAR TRANSMISSION

IO
306219
SHIM 3x6x1

IO
306219
SHIM 3x6x2

902254
SH M2.5x4

SET-UP BOOK
WHEELBASE

TIP Ensure that the rear upright moves freely. If it does not move freely, use sandpaper to thin both wheelbase adjustment shims.

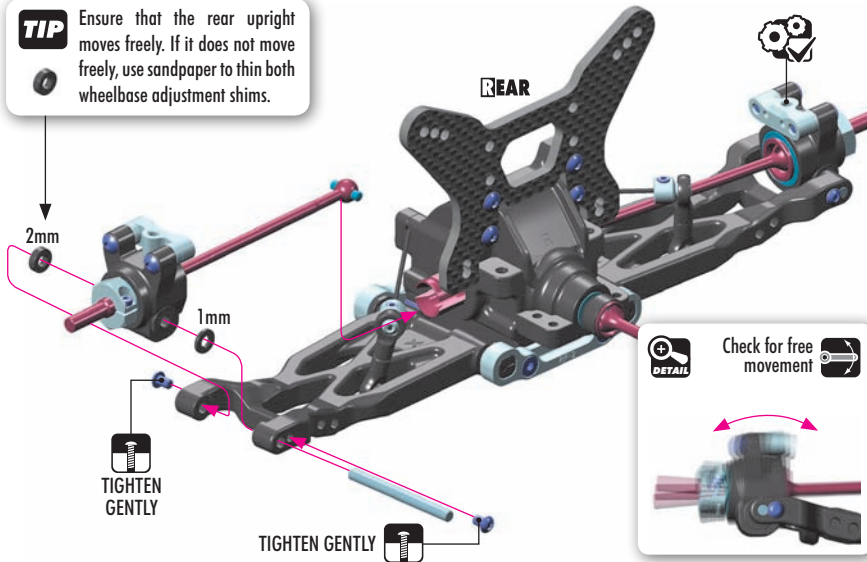

LONGER WHEELBASE

Adjustment Shim IN FRONT OF HUB moves hub rearward.

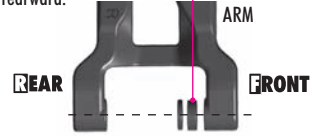

SHORTER WHEELBASE

Adjustment Shim BEHIND HUB moves hub forward.

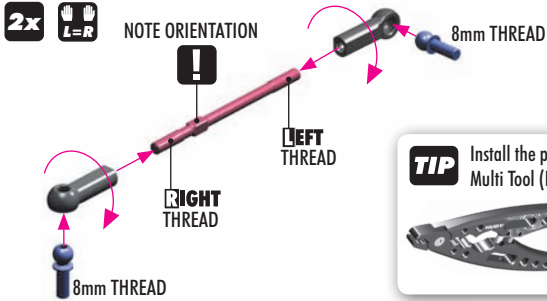
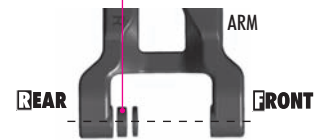

TIP Install the pivot balls with Professional Multi Tool (HUDY #183011)



SET-UP BOOK
CAMBER

303123
SHIM 3x6x2

362280
CON. SHIM 3x6x2

960030
N M3

SET-UP BOOK
ROLL CENTER

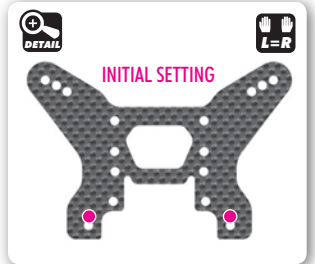
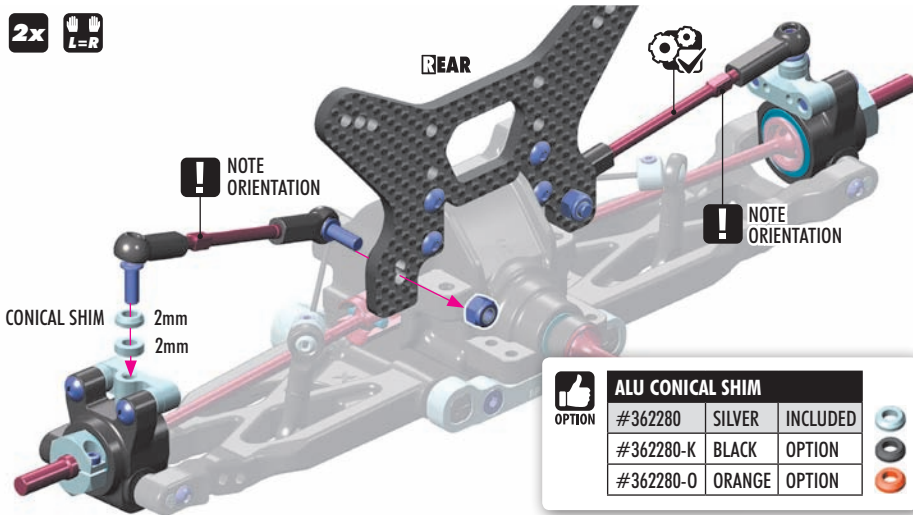

OPTION	ALU CONICAL SHIM		
	#362280	SILVER	INCLUDED
	#362280-K	BLACK	OPTION
	#362280-O	ORANGE	OPTION

902310
SH M3x10

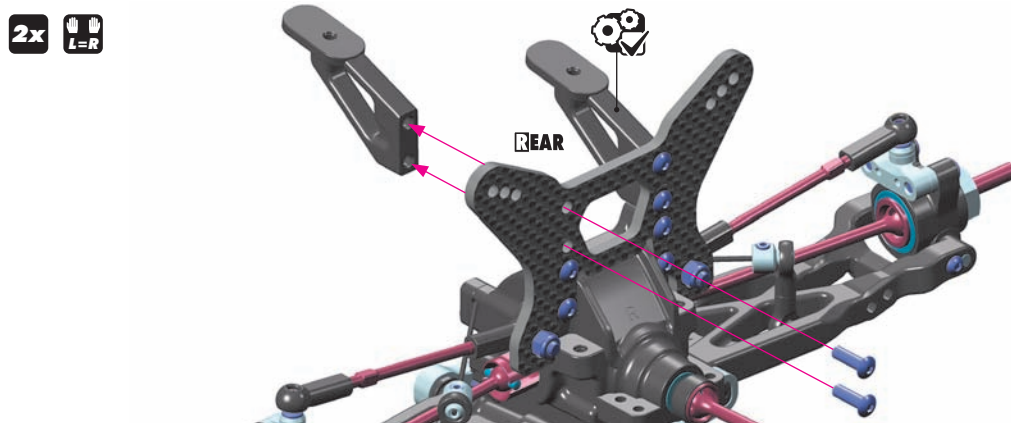

4. FRONT TRANSMISSION



WHEEL HUBS 12MM		
#365360	+4.5mm - (6 slots)	OPTION
#365359	+3.75mm (5 slots)	OPTION
#365358	+3.0mm (4 slots)	OPTION
#365357	+2.25mm (3 slots)	OPTION
#365356	+1.5mm (2 slots)	OPTION
#365355	+0.75mm (1 slot)	OPTION
#365353	0mm (0 slots)	INCLUDED
#365354	-0.75mm (Lightw.)	OPTION
#365361	-1.25mm (Lightw.)	OPTION



WHEEL HUBS 14MM		
#365352	+0.75mm	OPTION
#365350	0mm	OPTION
#365351	-0.75mm	OPTION



XRAY BALL-BEARING			
#940510	5x10x4	OIL	OPTION
#940512	5x12x4	OIL	OPTION
#359050	5x10x4	GREASE	INCLUDED
#940513	5x12x4	GREASE	INCLUDED



DRIVE SHAFT COLLAR		
#365470	COMPOSITE	INCLUDED
#365471-K	ALU - BLACK	OPTION
#365471-O	ALU - ORANGE	OPTION

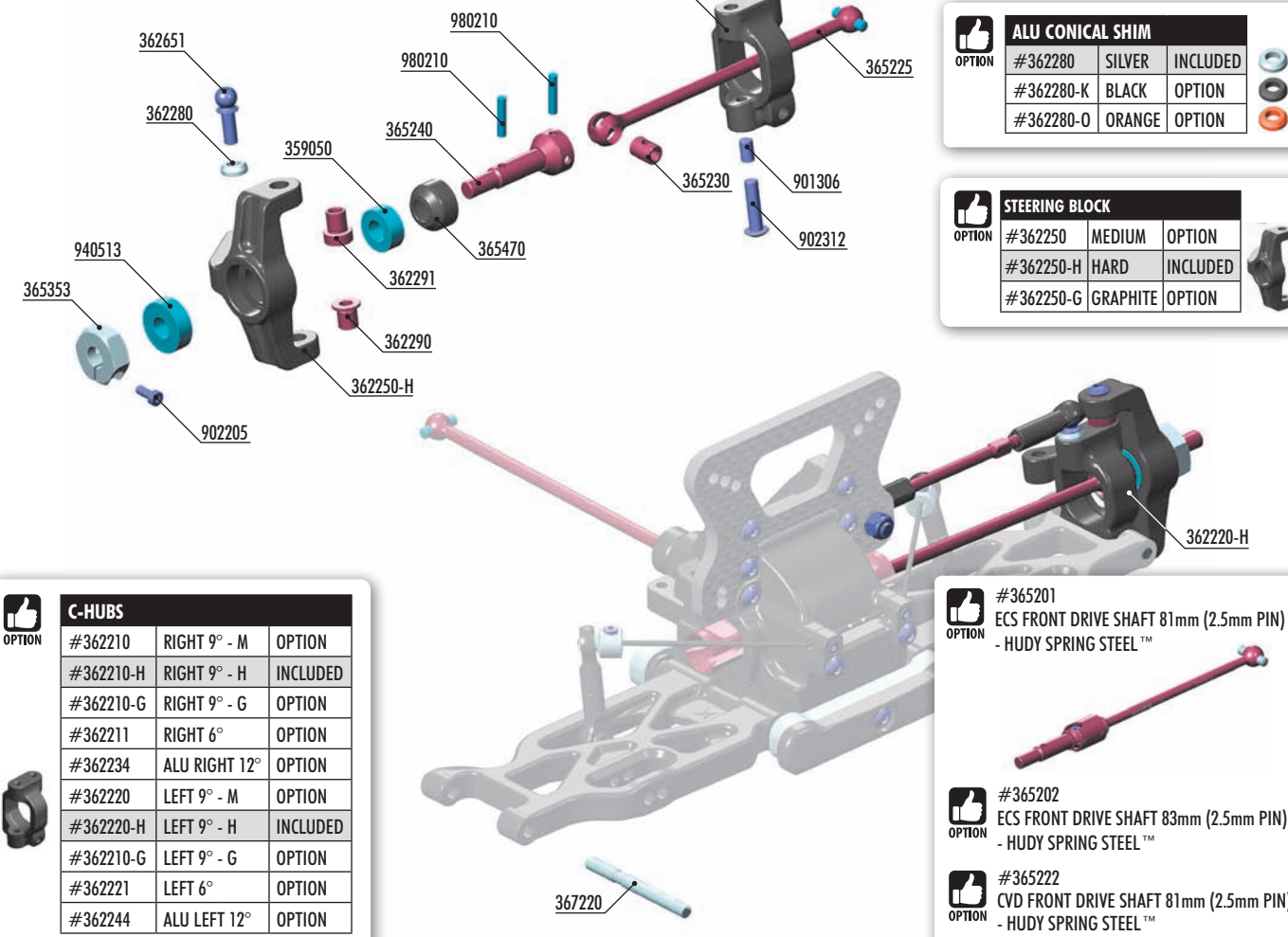

C-HUBS		
#362210	RIGHT 9° - M	OPTION
#362210-H	RIGHT 9° - H	INCLUDED
#362210-G	RIGHT 9° - G	OPTION
#362211	RIGHT 6°	OPTION
#362234	ALU RIGHT 12°	OPTION
#362220	LEFT 9° - M	OPTION
#362220-H	LEFT 9° - H	INCLUDED
#362210-G	LEFT 9° - G	OPTION
#362221	LEFT 6°	OPTION
#362244	ALU LEFT 12°	OPTION



- 302665 COMPOSITE BALL JOINT 4.9MM - CLOSED WITH HOLE (4)
- 362210-H COMPOSITE C-HUB 9° DEG. RIGHT - HARD
- 362220-H COMPOSITE C-HUB 9° DEG. LEFT - HARD
- 362250-H COMPOSITE STEERING BLOCK - HARD
- 362280 ALU CONICAL SHIM 3x6x2.0MM (10)
- 362290 STEEL STEERING BUSHING - SHORT (2)
- 362291 STEEL STEERING BUSHING - LONG (2)
- 362610 ADJ. TURNBUCKLE M3 L/R 50 MM - SPRING STEEL (2)
- 362651 BALL END 4.9MM WITH THREAD 8MM (2)
- 362652 BALL END 4.9MM WITH THREAD 10MM (2)
- 365225 FRONT DRIVE SHAFT 83MM WITH 2.5MM PIN - HUDY SPRING STEEL™
- 365230 DRIVE SHAFT COUPLING - HUDY SPRING STEEL™
- 365240 FRONT DRIVE AXLE - HUDY SPRING STEEL™

- 365353 ALU WHEEL HUB 12MM (2)
- 365470 COMPOSITE DRIVE SHAFT SAFETY COLLAR (3)
- 367220 FRONT ARM PIVOT PIN (2)
- 359050 BALL-BEARING 5x10x4 STEEL SEALED - GREASE (2)
- 901306 HEX SCREW SB M3x6 (10)
- 902205 HEX SCREW SH M2x5 (10)
- 902312 HEX SCREW SH M3x12 (10)
- 902314 HEX SCREW SH M3x14 (10)
- 940513 BALL-BEARING 5x12x4 RUBBER SEALED - GREASE (2)
- 960030 NUT M3 (10)
- 980210 PIN 2x10 (10)

ALU NUTS M3		
#296530-B	BLUE	OPTION
#296530-K	BLACK	OPTION
#296530-O	ORANGE	OPTION
#960031	SILVER	INCLUDED

ALU CONICAL SHIM		
#362280	SILVER	INCLUDED
#362280-K	BLACK	OPTION
#362280-O	ORANGE	OPTION

STEERING BLOCK		
#362250	MEDIUM	OPTION
#362250-H	HARD	INCLUDED
#362250-G	GRAPHITE	OPTION

#365201
ECS FRONT DRIVE SHAFT 81mm (2.5mm PIN) - HUDY SPRING STEEL™

#365202
ECS FRONT DRIVE SHAFT 83mm (2.5mm PIN) - HUDY SPRING STEEL™

#365222
CVD FRONT DRIVE SHAFT 81mm (2.5mm PIN) - HUDY SPRING STEEL™

4. FRONT TRANSMISSION

980210
P 2x10

2x L=R

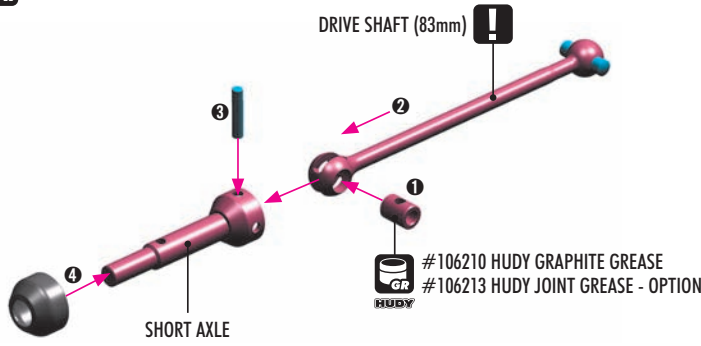

OPTION #365201
ECS FRONT DRIVE SHAFT 81mm (2.5mm PIN)
- HUDY SPRING STEEL™

OPTION #365202
ECS FRONT DRIVE SHAFT 83mm (2.5mm PIN)
- HUDY SPRING STEEL™

OPTION #365222
CVD FRONT DRIVE SHAFT 81mm (2.5mm PIN)
- HUDY SPRING STEEL™

359050
BB 5x10x4

940513
BB 5x12x4

Use HUDY Ball-Bearing Grease

#106220 - STANDARD
#106221 - BLUE
#106222 - RED



OPTION

XRAY BALL-BEARING

#940510	5x10x4	OIL	OPTION
#940512	5x12x4	OIL	OPTION
#359050	5x10x4	GREASE	INCLUDED
#940513	5x12x4	GREASE	INCLUDED

902205
SH M2x5

980210
P 2x10

2x L=R

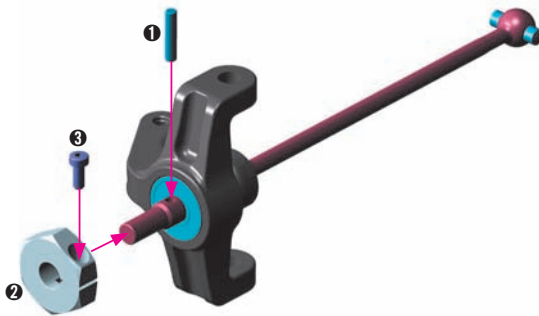

OPTION

WHEEL HUBS 12MM

#365360	+4.5mm (6 slots)	OPTION
#365359	+3.75mm (5 slots)	OPTION
#365358	+3.0mm (4 slots)	OPTION
#365357	+2.25mm (3 slots)	OPTION
#365356	+1.5mm (2 slots)	OPTION
#365355	+0.75mm (1 slot)	OPTION
#365353	0mm (0 slots)	INCLUDED
#365354	-0.75mm (Lightw.)	OPTION
#365361	-1.25mm (Lightw.)	OPTION

OPTIONAL HEX HUB EFFECTS

Different off-set hex hubs are used to increase or decrease the track-width.

LESS OFF-SET

Rear - more traction
Front - more steering

MORE OFF-SET

Rear - less traction
Front - less steering

362280
CON. SHIM 3x6x2

902312
SH M3x12

902314
SH M3x14

IMPORTANT

Be sure to use the shorter screw with shorter bushing and longer screw with longer bushing.

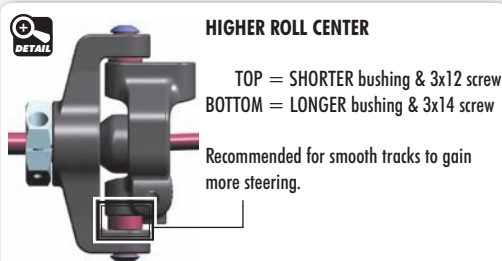
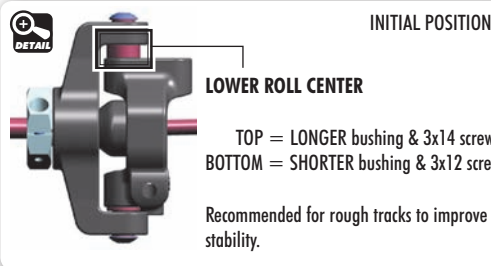
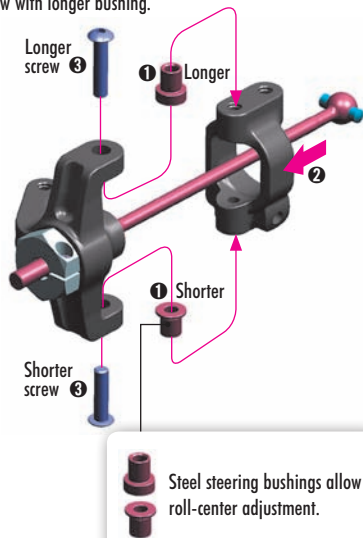

8mm
THREAD

NOTE
ORIENTATION

CONICAL SHIM
3x6x2mm



IMPORTANT

When inserting the bushings, make sure that bushings are inserted equally on both right and left hub to give the same roll center position.

SET-UP BOOK
CASTER
ROLL CENTER

4. FRONT TRANSMISSION



901306
SB M3x6

2x

L=R



DO NOT OVERTIGHTEN

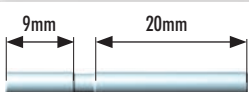

7:1 NOTE ORIENTATION

RIGHT

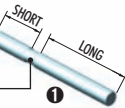

ARM REAMER (HUDY #107633) TIP L=R

If the C-hub does not move freely, use a HUDY Arm Reamer to resize the hole.



2x

L=R

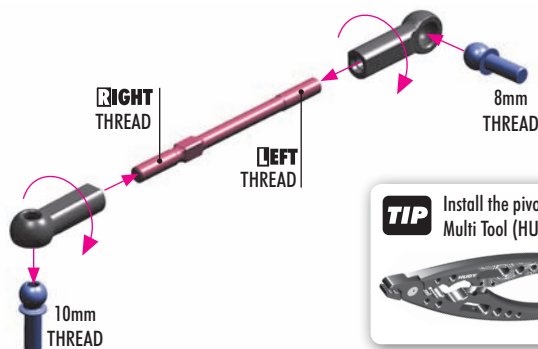

TIP Install the pivot balls with Professional Multi Tool (HUDY #183011)



SET-UP BOOK

CAMBER



362280
CON. SHIM 3x6x2



960030
N M3

2x

L=R

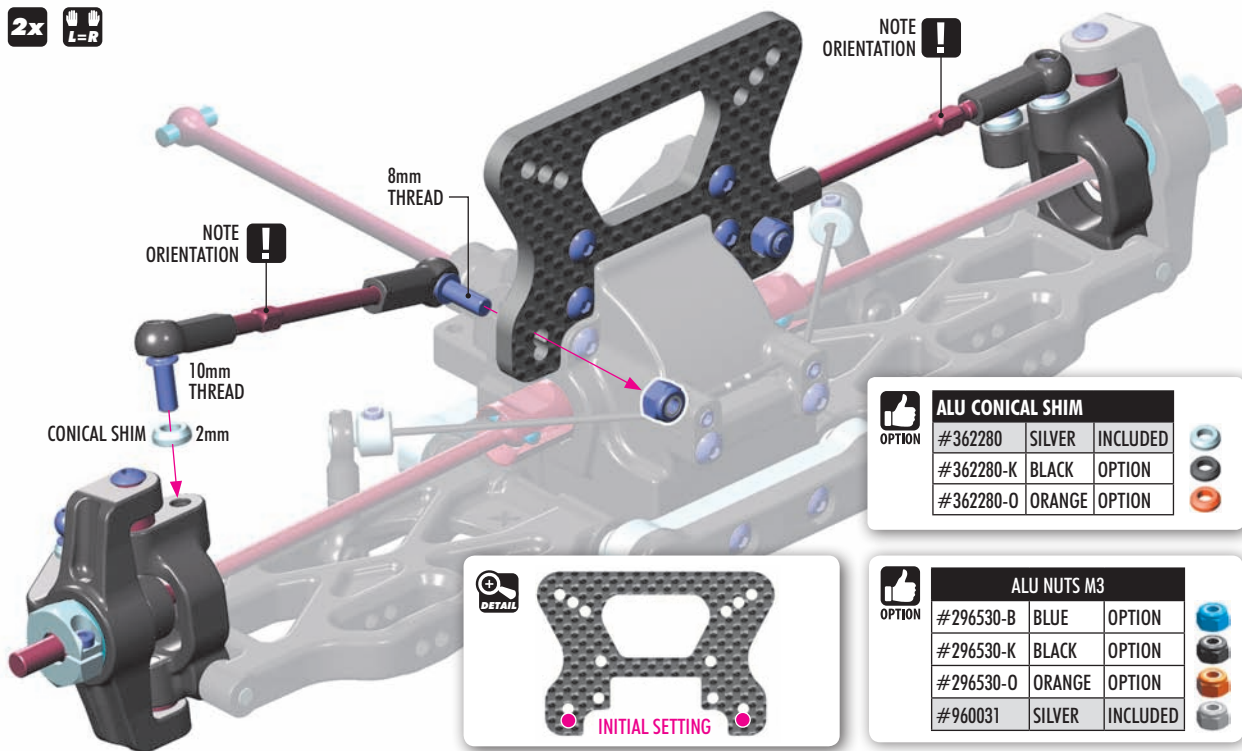

NOTE ORIENTATION

NOTE ORIENTATION

8mm THREAD

10mm THREAD

CONICAL SHIM 2mm

OPTION	ALU CONICAL SHIM		
	#362280	SILVER	INCLUDED
	#362280-K	BLACK	OPTION
	#362280-O	ORANGE	OPTION

DETAIL



INITIAL SETTING

OPTION	ALU NUTS M3		
	#296530-B	BLUE	OPTION
	#296530-K	BLACK	OPTION
	#296530-O	ORANGE	OPTION
	#960031	SILVER	INCLUDED

SET-UP BOOK

ROLL CENTER

4. FRONT & REAR ASSEMBLY

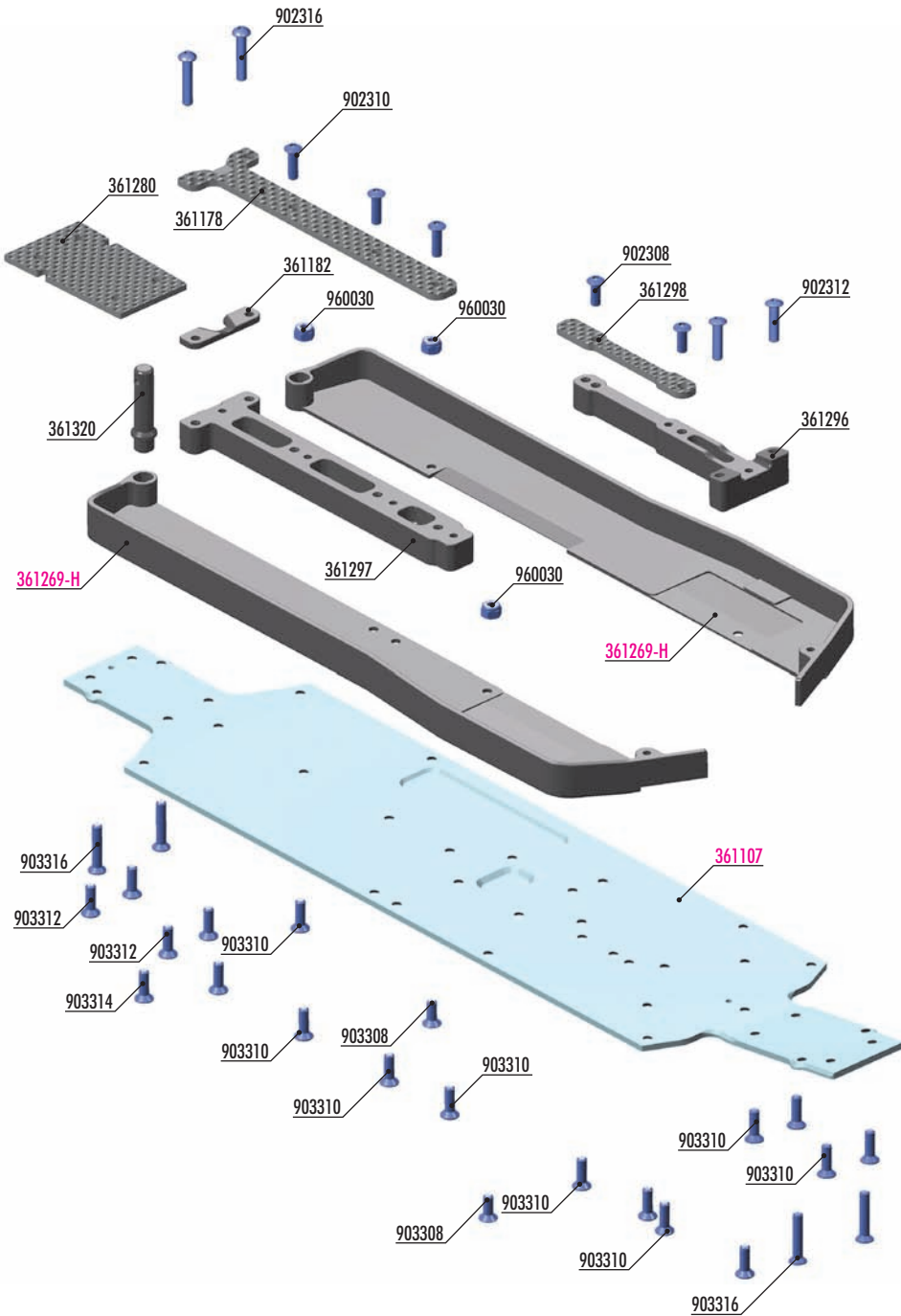

#361295
 COMPOSITE CHASSIS BRACE REAR - MEDIUM
 OPTION

#361179
 BRASS CHASSIS BRACE REAR (40g)
 OPTION

#361294
 COMPOSITE CHASSIS BRACE FRONT - MEDIUM
 OPTION

#361269-M
 COMPOSITE CHASSIS SIDE GUARDS
 L+R - MEDIUM
 OPTION

#361108
 ALU CHASSIS - SWISS 7075 T6 (2.5MM)
 OPTION

OPTION

ALU NUTS M3		
#296530-B	BLUE	OPTION
#296530-K	BLACK	OPTION
#296530-O	ORANGE	OPTION
#960031	SILVER	INCLUDED

BAG
04

- 361178 GRAPHITE CHASSIS BRACE UPPER DECK 2.0MM
- 361182 COMPOSITE REAR LOWER BRACE
- 361280 XB4'20 GRAPHITE REAR CHASSIS PLATE 2MM - NARROW
- 361296 COMPOSITE CHASSIS BRACE FRONT - HARD
- 361297 COMPOSITE CHASSIS BRACE REAR - HARD
- 361298 GRAPHITE CHASSIS WIRE COVER 2.0MM - V2
- 361320 BODY MOUNT, BATTERY MOUNT - V2 & WING SHIM (2)

- 902308 HEX SCREW SH M3x8 (10)
- 902310 HEX SCREW SH M3x10 (10)
- 902312 HEX SCREW SH M3x12 (10)

- 902316 HEX SCREW SH M3x16 (10)
- 903308 HEX SCREW SFH M3x8 (10)
- 903310 HEX SCREW SFH M3x10 (10)
- 903312 HEX SCREW SFH M3x12 (10)
- 903314 HEX SCREW SFH M3x14 (10)
- 903316 HEX SCREW SFH M3x16 (10)
- 960030 NUT M3 (10)

- 361107 ALU CHASSIS - SWISS 7075 T6 (2MM)
- 361269-H COMPOSITE CHASSIS SIDE GUARDS L+R - HARD

4. FRONT & REAR ASSEMBLY

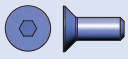

903308
SFH M3x8

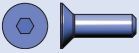

903310
SFH M3x10



903314
SFH M3x14



960030
N M3

SET-UP BOOK

CHASSIS FLEX

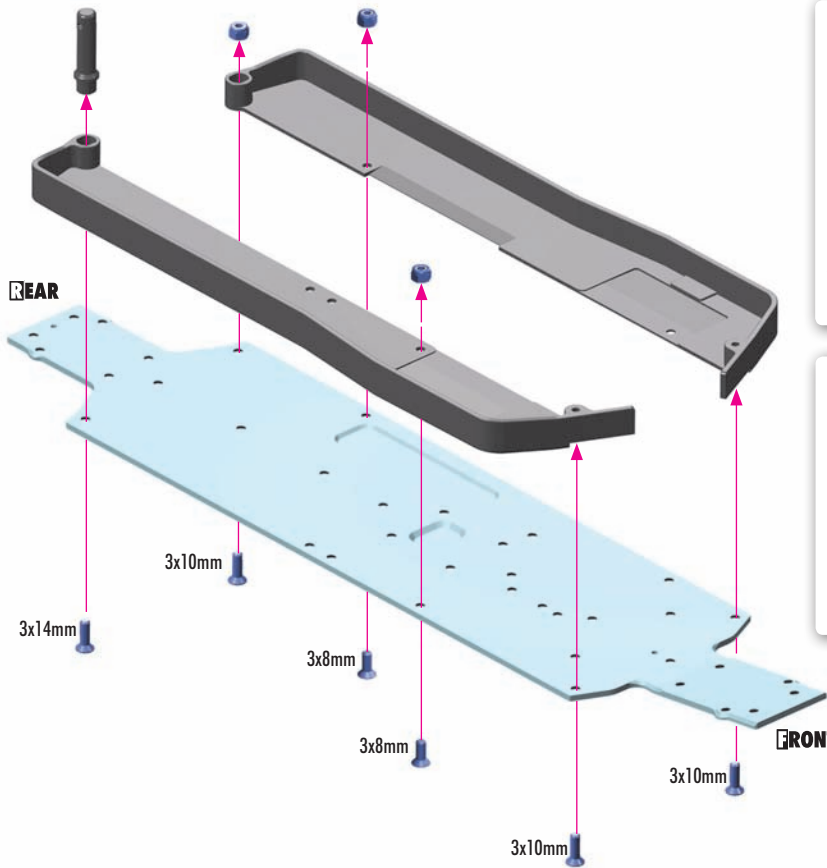

#361269-M
COMPOSITE CHASSIS SIDE GUARDS L+R (MEDIUM)



The medium side guards increase chassis flex and are recommended for low-traction tracks.



#361108
ALU CHASSIS - SWISS 7075 T6 (2.5MM)

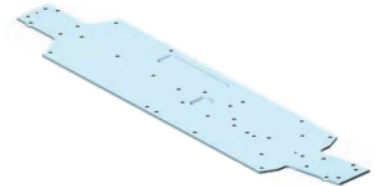

ALU NUTS M3

#296530-B	BLUE	OPTION
#296530-K	BLACK	OPTION
#296530-O	ORANGE	OPTION
#960031	SILVER	INCLUDED

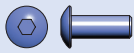

902308
SH M3x8



902310
SH M3x10

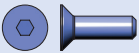

903310
SFH M3x10

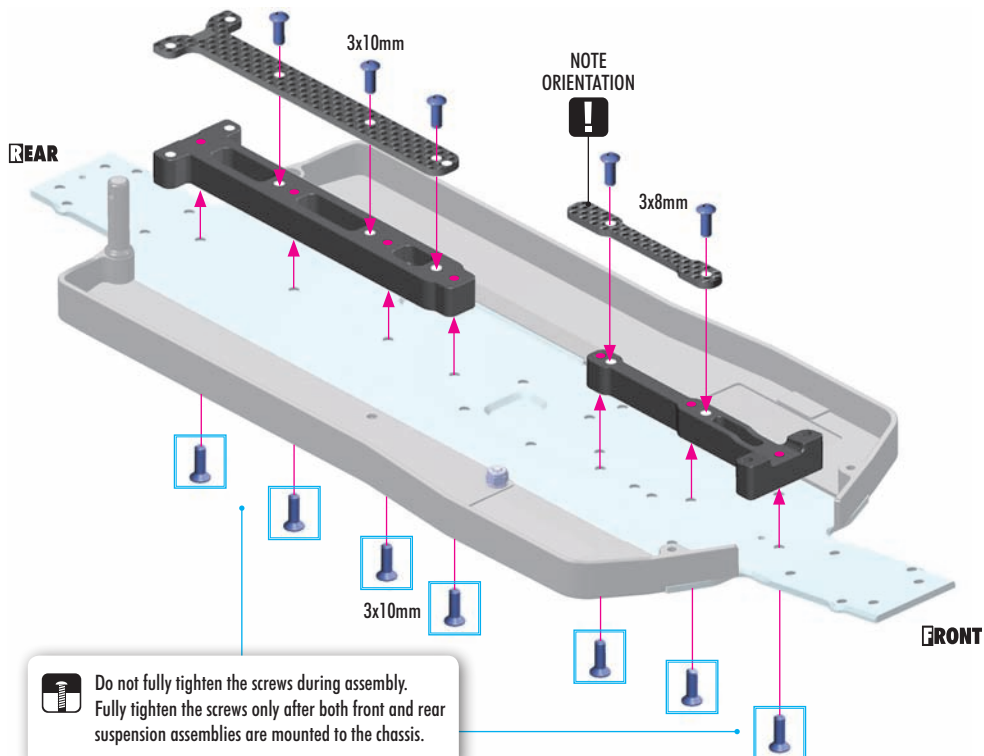

Do not fully tighten the screws during assembly.
Fully tighten the screws only after both front and rear suspension assemblies are mounted to the chassis.



#361179
BRASS CHASSIS BRACE REAR (40g)



#361295
COMPOSITE CHASSIS BRACE REAR - MEDIUM



#361294
COMPOSITE CHASSIS BRACE FRONT - MEDIUM



4. FRONT & REAR ASSEMBLY



902316
SH M3x16



903310
SFH M3x10



903316
SFH M3x16

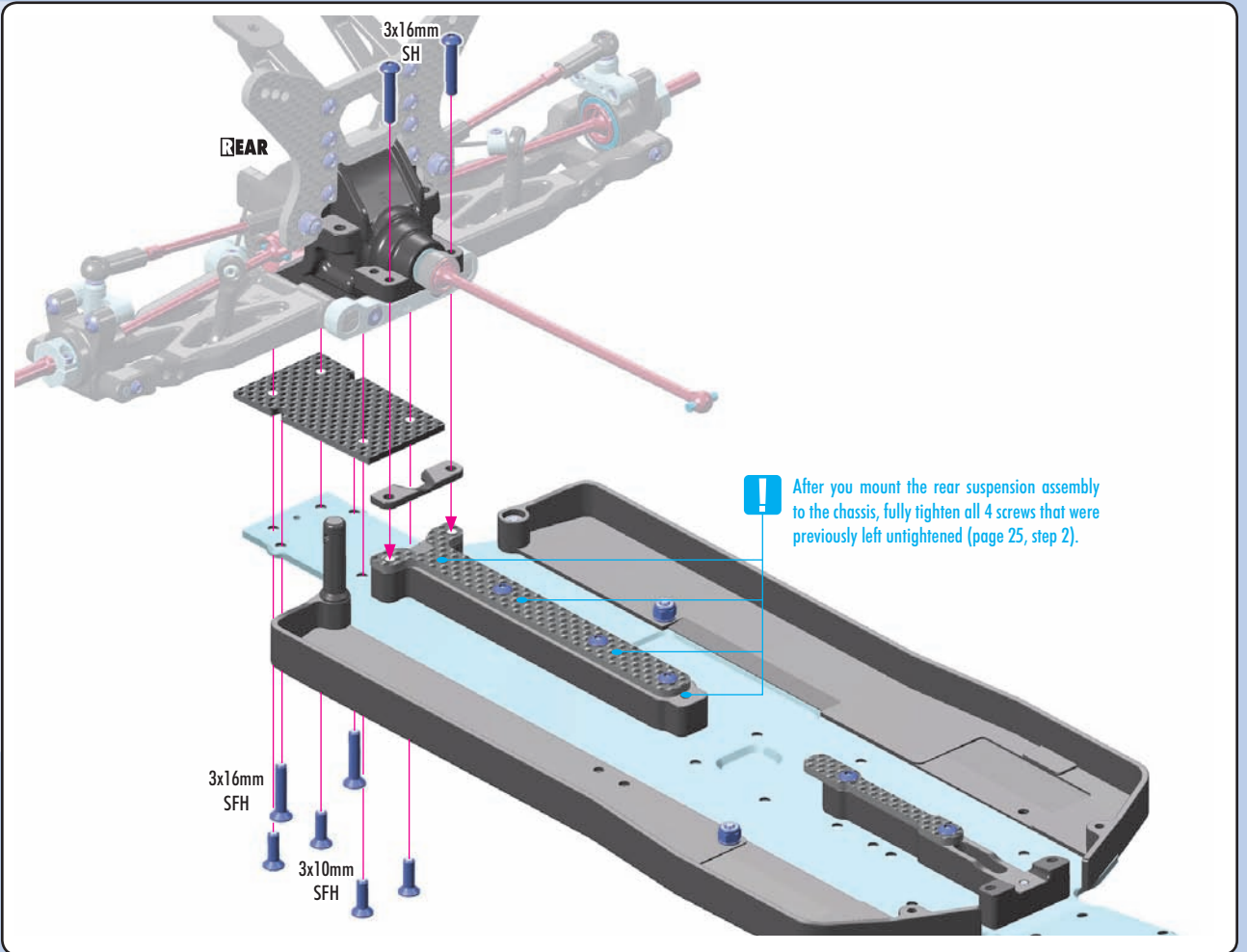

902312
SH M3x12



903310
SFH M3x10



903316
SFH M3x16

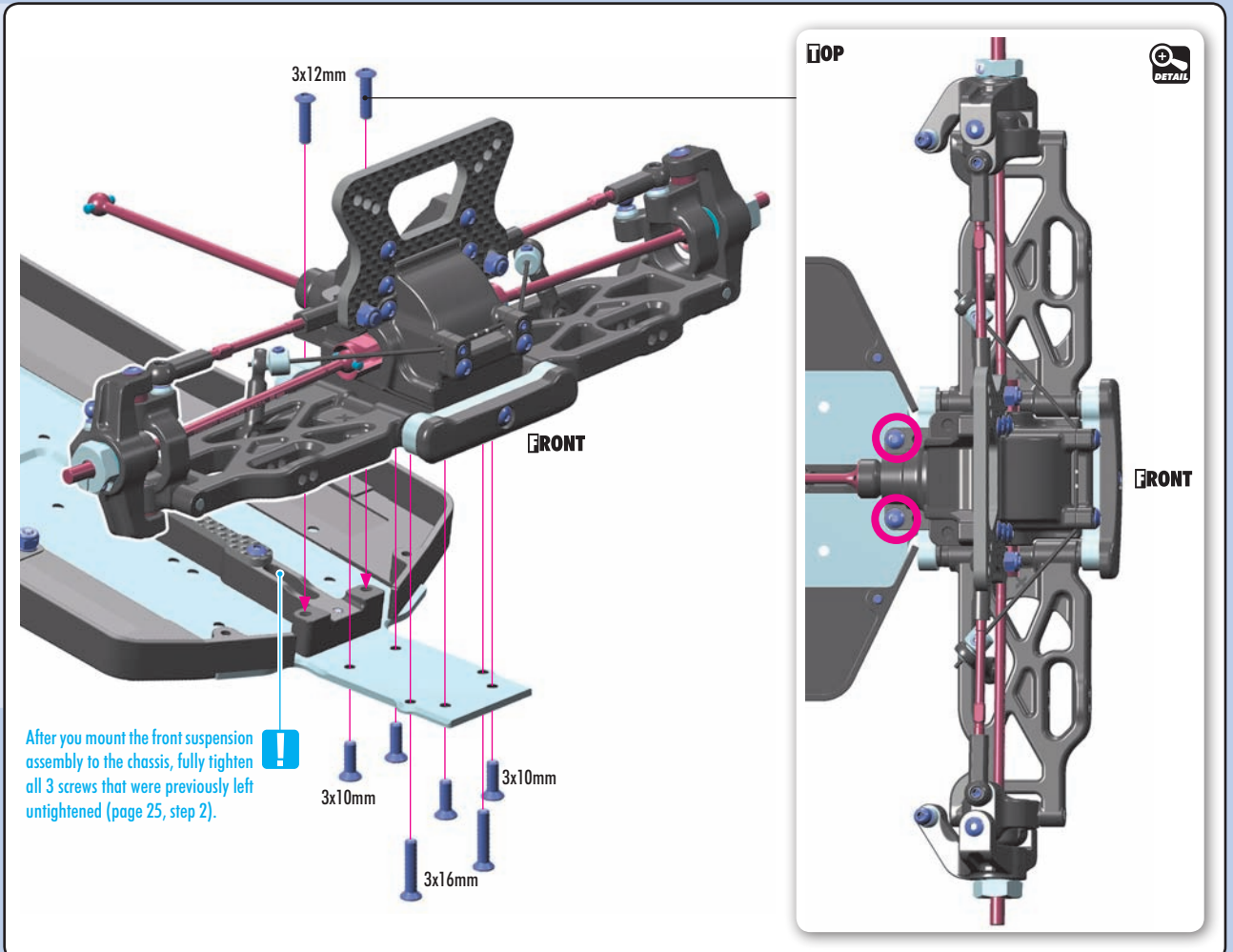

5. STEERING

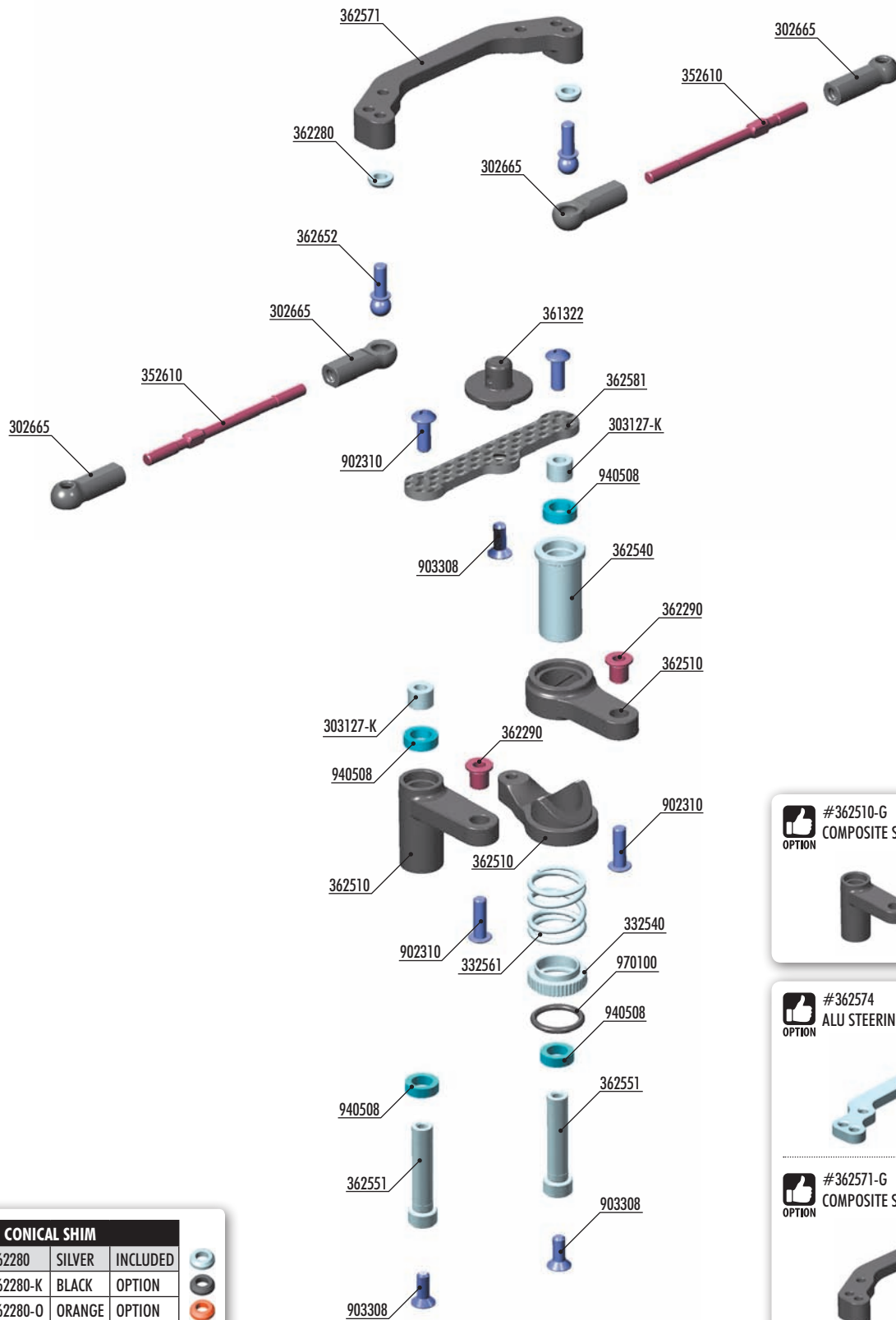

ALU CONICAL SHIM			
#362280	SILVER	INCLUDED	
#362280-K	BLACK	OPTION	
#362280-O	ORANGE	OPTION	

BAG
05

- 302665 COMPOSITE BALL JOINT 4.9MM - CLOSED WITH HOLE (4)
- 303127-K ALU SHIM 3x6x4.0MM - BLACK (10)
- 332540 ALU SERVO SAVER ADJUSTABLE NUT
- 332561 SERVO SAVER SPRING C=14
- 352610 ADJ. TURNBUCKLE M3 L/R 45MM - SPRING STEEL (2)
- 361322 BODY MOUNT - EXTRA-SHORT
- 362280 ALU CONICAL SHIM 3x6x2.0MM (10)
- 362290 STEEL STEERING BUSHING - SHORT (2)
- 362510 COMPOSITE SERVO SAVER
- 362540 ALU SERVO SAVER MAIN SHAFT
- 362551 SERVO SAVER PIVOT SHAFT +2MM (2)

- 362571 COMPOSITE STEERING PLATE
- 362581 STEERING BRACE 2.0MM GRAPHITE
- 362652 BALL END 4.9MM WITH THREAD 10MM (2)
- 902310 HEX SCREW SH M3x10 (10)
- 903308 HEX SCREW SFH M3x8 (10)
- 940508 BALL-BEARING 5x8x2.5 RUBBER SEALED - OIL (2)
- 970100 O-RING 10 x 1.5 (10)

5. STEERING



970100
O 10x1.5

SET-UP BOOK

SERVO SAVER

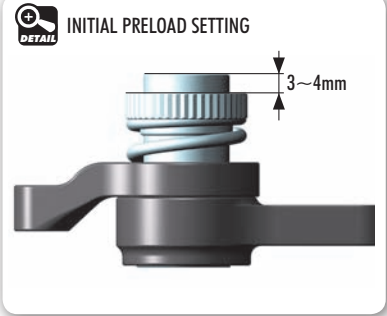
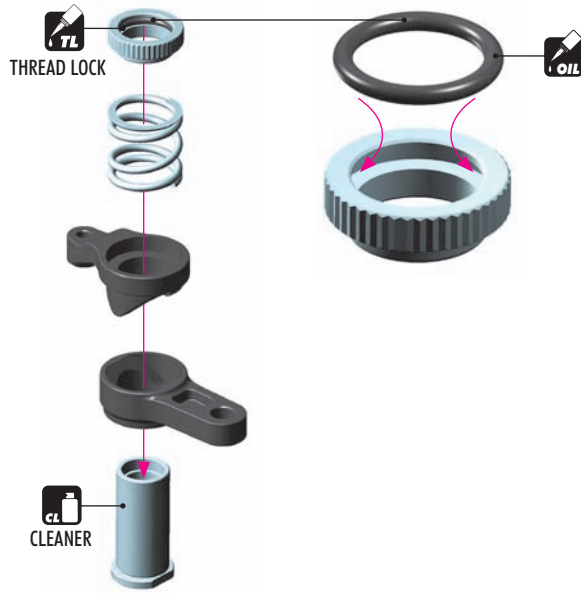

902310
SH M3x10

NOTE ORIENTATION

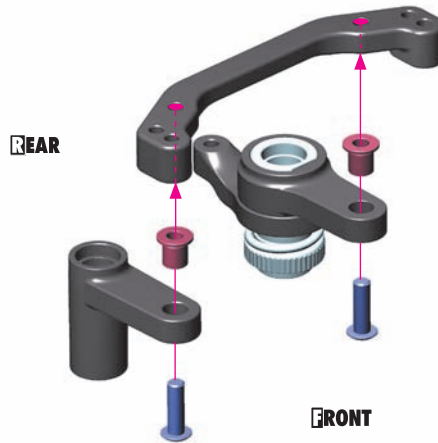

OPTION	STEERING PLATE	
#362571	HARD	INCLUDED
#362571-G	GRAPHITE	OPTION
#362574	ALU	OPTION



Increases steering precision and predictability and is recommended for use in high-traction conditions. Includes extra Ackermann positions for very precise steering adjustment.



902310
SH M3x10



303127-K
SHIM 3x6x4



903308
SFH M3x8



940508
BB 5x8x2.5

NOTE ORIENTATION

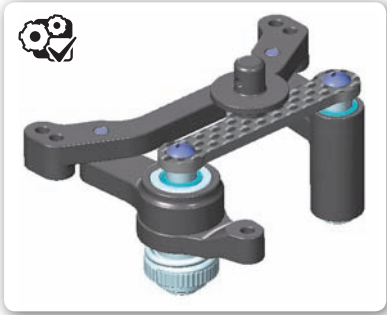
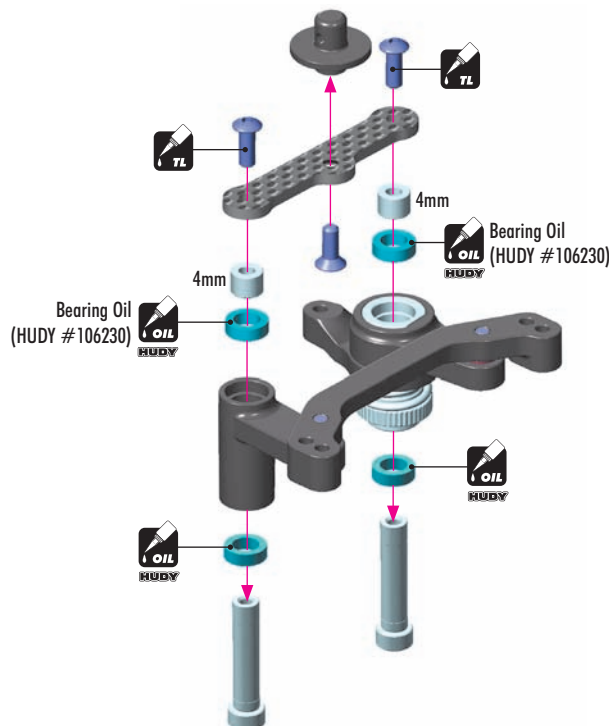

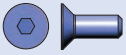

903308
SFH M3x8

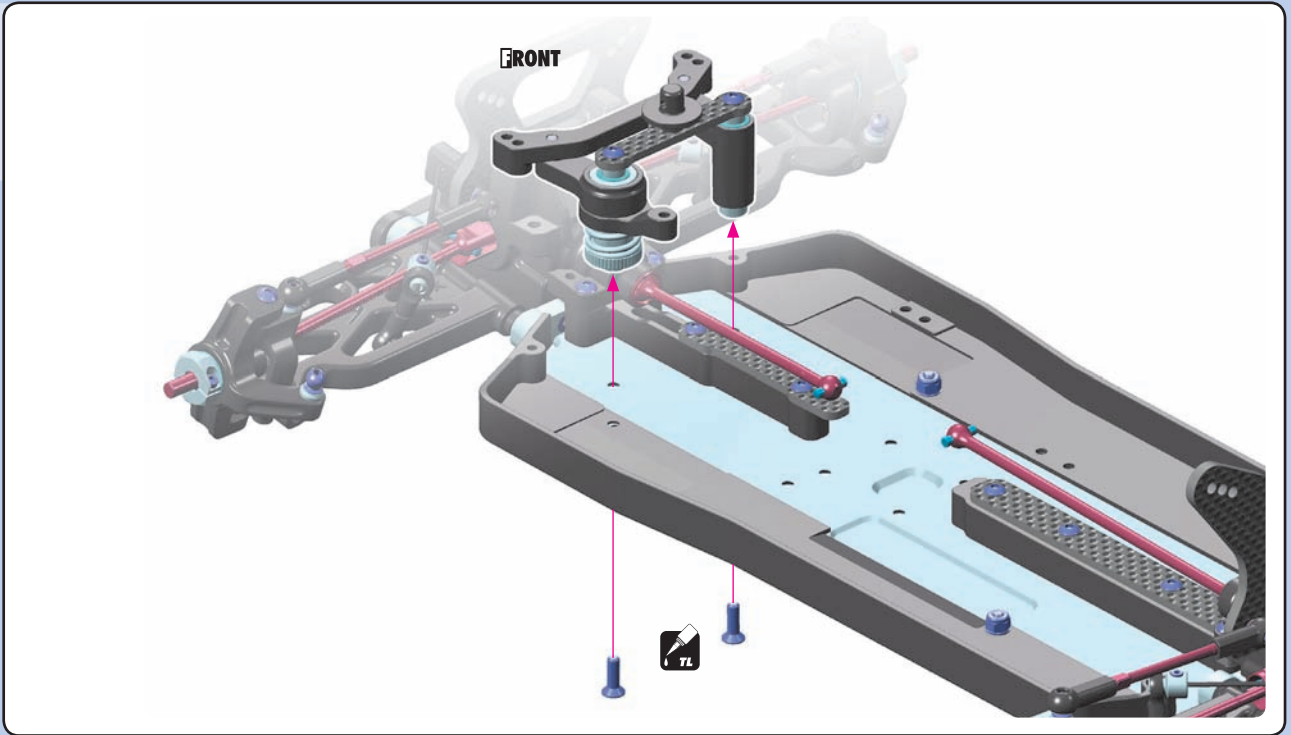

2x

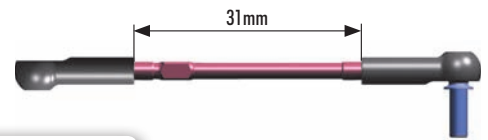
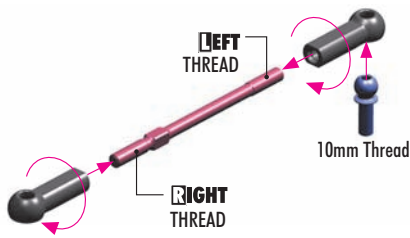

TIP Install the pivot balls with Professional Multi Tool (HUDY #183011)



362280
CON. SHIM 3x6x2

2x

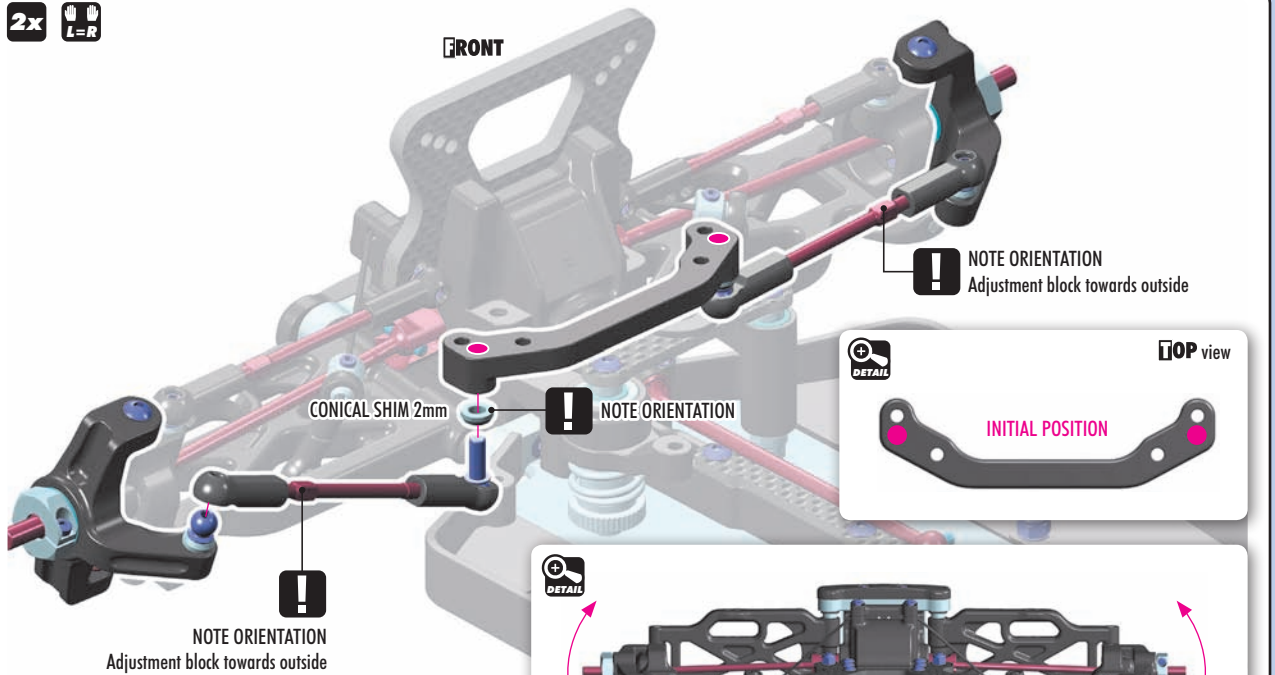

NOTE ORIENTATION
Adjustment block towards outside



OPTION	ALU CONICAL SHIM		
#362280	SILVER	INCLUDED	
#362280-K	BLACK	OPTION	
#362280-O	ORANGE	OPTION	

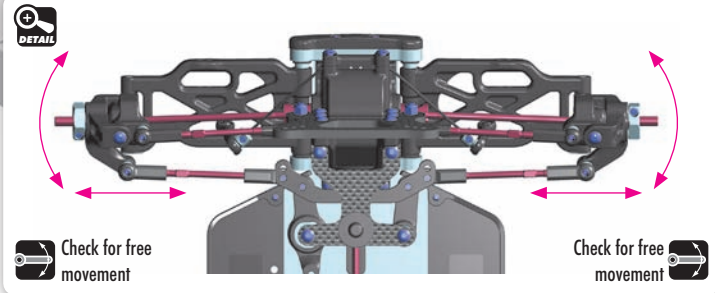

SET-UP BOOK
ACKERMANN
BUMP STEER
TOE-IN

6. SLIPPER CLUTCH ASSEMBLY

#364904
OPTION
GEAR CENTER DIFFERENTIAL - SET

#364024
OPTION
ALU CENTRAL BULKHEAD

SLIPPER CLUTCH SPUR GEARS

#365875	75T / 48	OPTION
#365878	78T / 48	OPTION
#365881	81T / 48	INCLUDED
#365884	84T / 48	OPTION
#365887	87T / 48	OPTION

<p>BAG</p> <p>06</p>	361176	XB4'20 GRAPHITE CENTER UPPER DECK 2MM	365881	COMPOSITE SLIPPER CLUTCH SPUR GEAR 81T / 48 - GRAPHITE
	361188	XB4'20 GRAPHITE REAR UPPER BRACE 2MM	901304	HEX SCREW SB M3x4 (10)
	361320	BODY MOUNT, BATTERY MOUNT - V2 & WING SHIM (2)	902304	HEX SCREW SH M3x4 (10)
	364013	ALU MOTOR BULKHEAD - LOWER	902306	HEX SCREW SH M3x6 (10)
	364023	COMPOSITE CENTRAL BULKHEAD - LOWER	902308	HEX SCREW SH M3x8 (10)
	364113	3-PAD SLIPPER CLUTCH SHAFT - NARROW - HUDY SPRING STEEL™	902318	HEX SCREW SH M3x18 (10)
	364120	ALU SLIPPER CLUTCH PLATE - 7075 T6 BLACK HARD COATED	903308	HEX SCREW SFH M3x8 (10)
	364121	ALU 3-PAD SLIPPER CLUTCH PLATE WITH ADAPTER - 7075 T6 HARD COATED	941015	BALL-BEARING 10x15x4 RUBBER SEALED - OIL (2)
	364131	SLIPPER CLUTCH PAD "SLS" (2)	980212	PIN 2x11.6 (10)
	364140	ALU 3-PAD SLIPPER CLUTCH PLATE DISC - 7075 T6 HARD COATED	981208	PIN 2x8 (10)
	364172	SLIPPER CLUTCH OUTDRIVE ADAPTER - NARROW - HUDY SPRING STEEL™		
	364182	SLIPPER CLUTCH SPRING C=46 - BLACK		
	364190	ALU SLIPPER CLUTCH NUT - V2		

901304
SB M3x4

980212
P 2x11.6

NOTE ORIENTATION

902304
SH M3x4

981208
P 2x8

VERY IMPORTANT!
It is very important that you NEVER FULLY TIGHTEN the Slipper Clutch. Overtightening the Slipper Clutch may result in breakage of the diff crown gear and pinion gear.

0~0.5mm

SLIPPER ADJUSTMENT:
The Slipper Clutch is easily adjusted by the set-screw in the bushing. The more the spring is tightened (bushing moved more inwards), the more the Slipper Clutch is tightened.

INITIAL INSTALLATION POSITION SHOWN
Detailed information on slipper adjustment can be found on page 32.

6. SLIPPER CLUTCH ASSEMBLY

-  902318
SH M3x18
-  903308
SFH M3x8

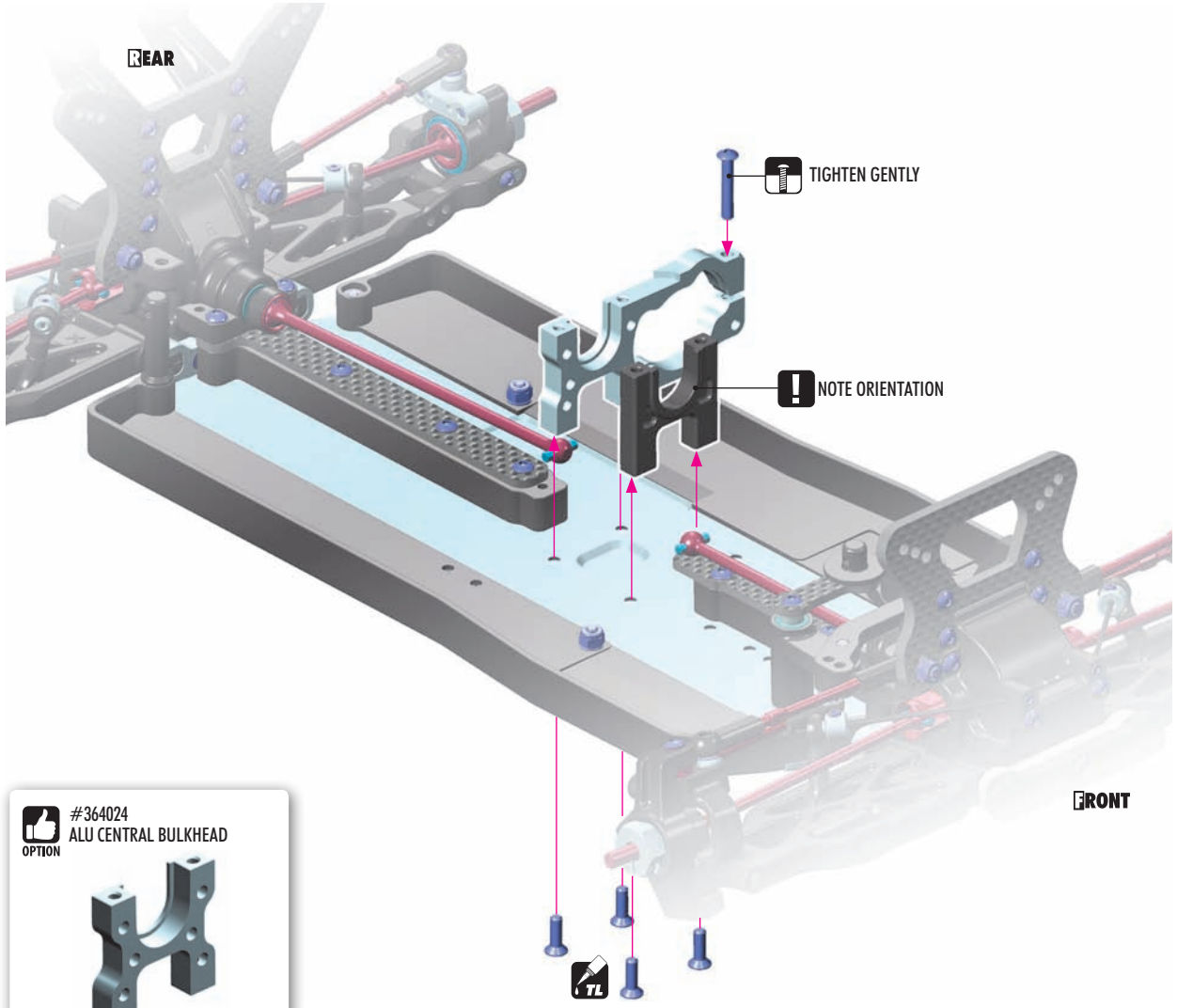



REAR

TIGHTEN GENTLY

NOTE ORIENTATION

FRONT

 #364024
ALU CENTRAL BULKHEAD
OPTION



-  941015
BB 10x15x4

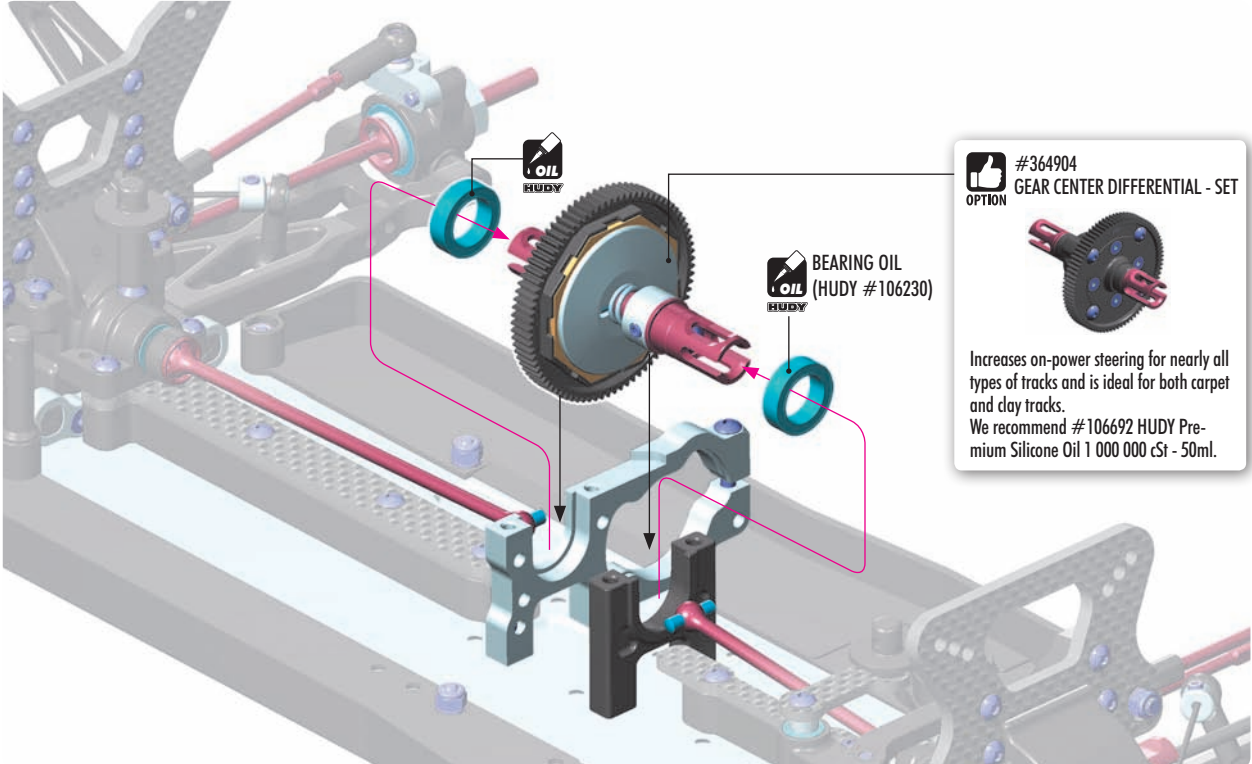

OIL HUDY

BEARING OIL (HUDY #106230)

 #364904
GEAR CENTER DIFFERENTIAL - SET
OPTION

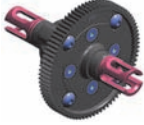

Increases on-power steering for nearly all types of tracks and is ideal for both carpet and clay tracks.
We recommend #106692 HUDY Premium Silicone Oil 1 000 000 cSt - 50ml.

6. SLIPPER CLUTCH ASSEMBLY

SLIPPER CLUTCH ADJUSTMENT

The Slipper Clutch can be adjusted by loosening the set-screw and then, while keeping the tool inside of the set-screw, rotating the spur gear by hand as indicated in the drawing.

To **LOOSEN**: Rotate the spur gear in the counterclockwise (CCW) direction.
To **TIGHTEN**: Rotate the spur gear in the clockwise (CW) direction.

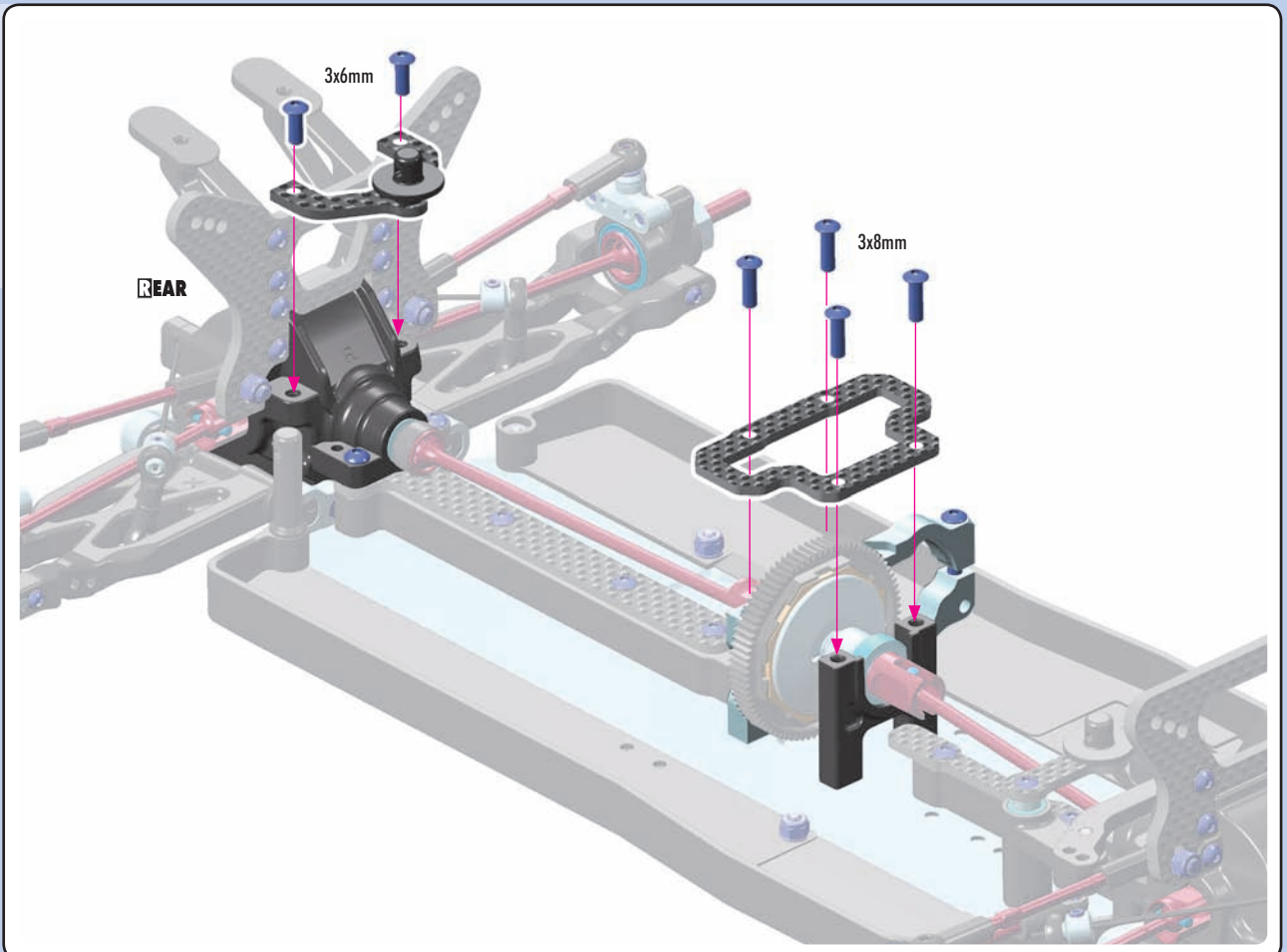
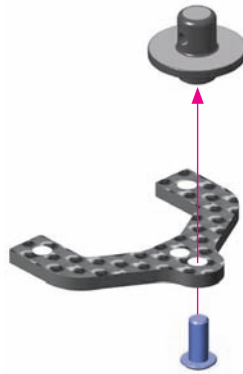
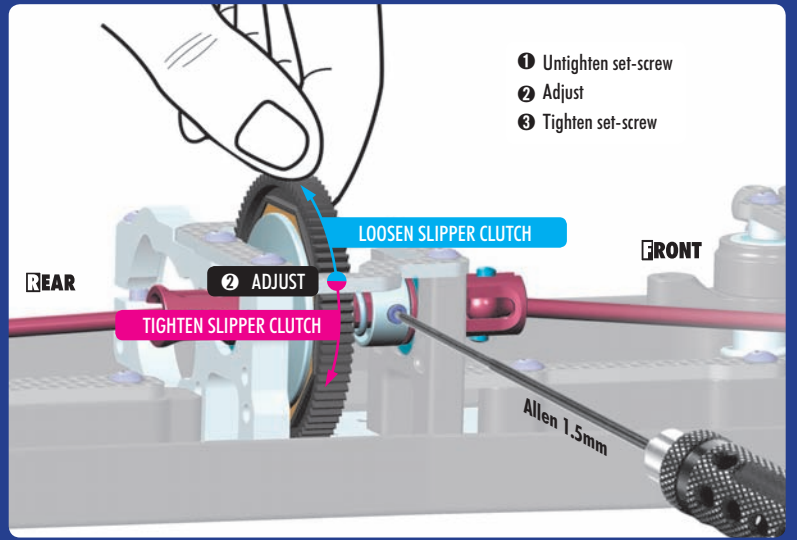

7. SHOCK ABSORBERS

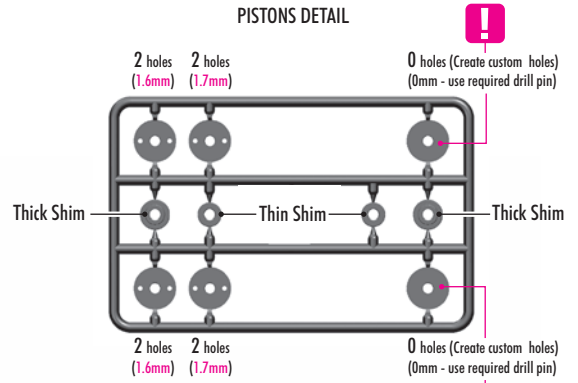
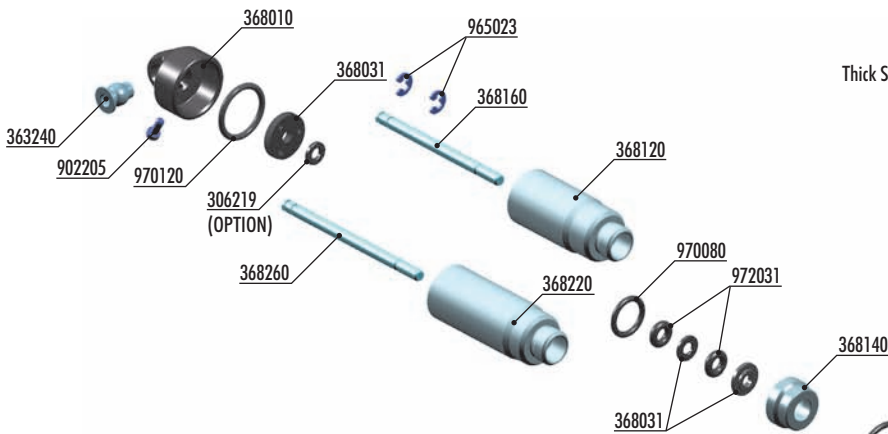

!
These pistons can NOT be used in shocks without making the custom holes by yourselves.

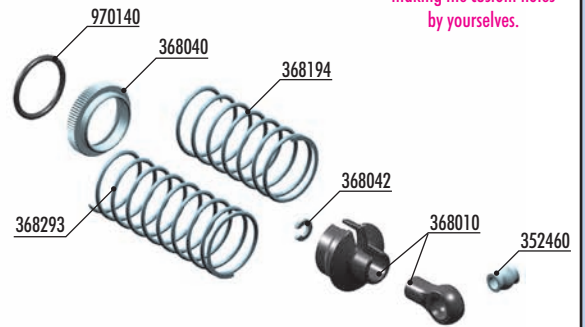

FRONT SPRINGS

#368191	LINEAR	42mm	1 DOTS	OPTION
#368192	LINEAR	42mm	2 DOTS	OPTION
#368193	LINEAR	42mm	3 DOTS	OPTION
#368194	LINEAR	42mm	4 DOTS	OPTION
#368195	LINEAR	42mm	5 DOTS	OPTION



REAR SPRINGS

#368292	LINEAR	57mm	2 DOTS	OPTION
#368293	LINEAR	57mm	3 DOTS	OPTION
#368294	LINEAR	57mm	4 DOTS	OPTION



FRONT SPRINGS

#368174	PROGRESS. 45mm	2 STRIPES	OPTION
#368175	PROGRESS. 40mm	3 DOTS	OPTION
#368182	LINEAR 45mm	1 STRIPE & 3 DOTS	OPTION
#368183	LINEAR 45mm	1 DOT	OPTION
#368184	LINEAR 45mm	2 DOTS	OPTION
#368185	LINEAR 45mm	3 DOTS	INCLUDED
#368186	LINEAR 45mm	4 DOTS	OPTION



REAR SPRINGS

#368273	PROGRESS. 60mm	2 STRIPES	OPTION
#368275	PROGRESS. 55mm	2 DOTS	OPTION
#368283	LINEAR 63mm	1 STRIPE & 3 DOTS	OPTION
#368284	LINEAR 60mm	1 DOT	OPTION
#368285	LINEAR 60mm	2 DOTS	INCLUDED
#368286	LINEAR 60mm	3 DOTS	OPTION
#368287	LINEAR 60mm	4 DOTS	OPTION



#368051
ALU SHOCK CAP-NUT WITH VENT HOLE (2)



#104004
HUDY AIR VAC - VACUUM PUMP - 1/10 OFF-ROAD



#368021
ALU SHOCK SPRING RETAINING COLLAR (4)



BAG

07

306219 COMPOSITE SET OF SERVO SHIMS (4)
352460 PIVOT BALL 5.8 - V3 (10)
363240 BALL UNIVERSAL 5.8MM WITH BACKSTOP (2)
368010 COMPOSITE SHOCK PARTS
368031 SHOCK PISTONS - COMPLETE SET - DERLIN - V2
368040 ALU SHOCK ADJUSTABLE NUT (2)
368042 COMPOSITE SHOCK BUSHING & SHIM FOR ALU CAP (2+2)
368100 FRONT SHOCK ABSORBERS COMPLETE SET (2)
368120 ALU FRONT SHOCK BODY - HARD COATED (2)
368140 ALU LOWER SHOCK BODY CAP (2)
368160 FRONT HARDENED SHOCK SHAFT (2)
368194 FRONT SPRING SET L=42MM (4 DOTS) (2)
368200 REAR SHOCK ABSORBERS COMPLETE SET (2)
368220 ALU REAR SHOCK BODY - HARD COATED (2)
368260 REAR HARDENED SHOCK SHAFT (2)

368293 REAR SPRING SET L=57MM (3 DOTS) (2)
902205 HEX SCREW SH M2x5 (10)
965023 E-CLIP 2.3 (10)
970080 O-RING 8x1 (10)
970120 O-RING 12 x 1.0 (10)
970140 O-RING 14 x 1.5 (10)
972031 SILICONE O-RING 3x2.1 (10)

7. SHOCK ABSORBERS



965023
C 2.3



970080
O 8x1



972031
O 3x2.1

SET-UP BOOK

SHOCK DAMPING
SHOCK PISTONS

FRONT - SHORT SHOCK ROD
2 holes (1.6mm) **2x FRONT**

REAR - LONG SHOCK ROD
2 holes (1.7mm) **2x REAR**

INITIAL PISTON SETTING

4x

There are two different thickness shims, use them as shown. Use the same procedure when building both front and rear shocks.

THICK Shim

O-ring

THIN Shim

O-ring

#306219
OPTION
DOWNSTOP SHIMS

THICKER shim used, GREATER downstop is achieved.

1mm 2mm 3mm

! IMPORTANT

Always use same shim thickness on right and left side to achieve same downstop.

! EXTREMELY IMPORTANT

INCORRECT

CORRECT

Do not push the shock rod straight through the lower shock body assembly; O-ring damage may result.

Twist the shock rod through the lower shock body assembly.

INITIAL SETTING (0mm)

2x FRONT SHOCKS

SHORT SHOCK ROD

SHORT SHOCK BODY

INITIAL SETTING (0mm)

2x REAR SHOCKS

LONG SHOCK ROD

LONG SHOCK BODY

970140
O 14x1.5

4x

970120
O 12x1

UP-STOP "C" SHIMS

INITIAL SETTING

FRONT **REAR**

0mm **FRONT**

2mm **REAR**

UP-STOP SHIM

INITIAL SETTING

24mm **FRONT**

29mm **REAR**

TIP Install the pivot balls with Professional Multi Tool (HUDY #183011)

7. SHOCK ABSORBERS

IMPORTANT

UP-STOP TRAVEL SETTINGS

It is very important to have properly set the up-stop travel to avoid damage to the drive shaft and diff outdrives.

To avoid collision of the drive shaft with diff outdrives use the up-stop travel shims to set-up the up-stop travel.

All these settings have influence on the up-stop travel:

- Length of arms (long/short)
- Length of drive shafts
- Shock positions
- Eccentric bushings in suspension holders
- Eccentric bushings in rear uprights
- Camber

UP-STOP SHIM

UP-STOP TRAVEL

ENSURE NO COLLISION !

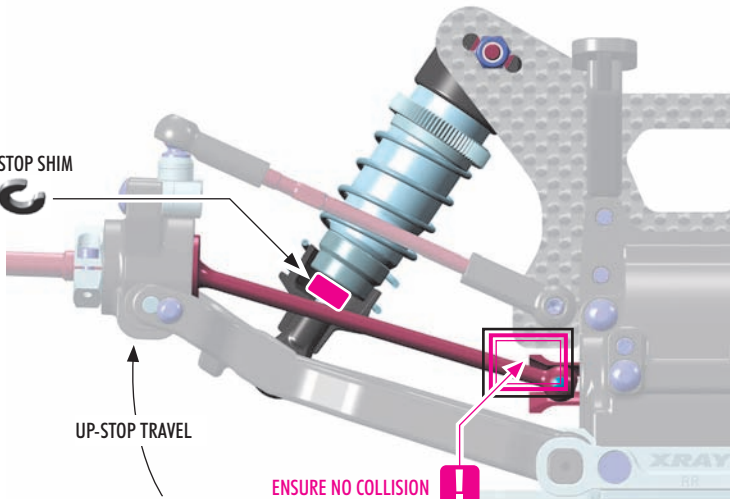

DEFAULT SHOCK REBOUND SETTING 0% REBOUND

2x FRONT (SHORT)
Oil 700cSt

2x REAR (LONG)
Oil 500cSt

1 Extend the shock shaft completely. Fill the shock body with the shock oil. For the FRONT shocks use 700cSt oil. For the REAR shocks use 500cSt oil.

2 Move the shock shaft up and down a few times to release the air bubbles trapped beneath the piston.

3 Orient the filled shock vertically for several minutes with the shock shaft fully extended. The remaining air bubbles will release.

4 Gently place the shock cap onto the filled shock body and start to tighten the cap fully.

5 Gently push the shock shaft completely into the shock body. Excess oil will flow through the hole in the shock cap.

6 Keep the shock shaft pushed in the shock body and insert the screw into the shock cap. Tighten gently.

7 6x push the shaft up and down.

8 Untighten the screw.

9 Gently push the shock shaft completely into the shock body. Excess oil will flow through the hole in the shock cap.

10 Tighten the screw. The rebound will be at approx. 0%.

902205 SH M2x5

Keep the shock shaft pushed in the shock body and insert the screw into the shock cap. Tighten gently.

6x push the shaft up and down.

Untighten the screw.

Gently push the shock shaft completely into the shock body. Excess oil will flow through the hole in the shock cap.

Tighten the screw. The rebound will be at approx. 0%.

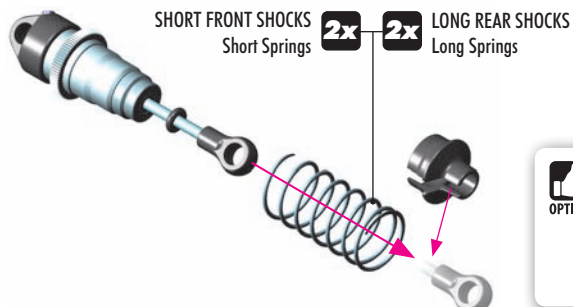

2x FRONT SHOCKS (SHORT)
2x REAR SHOCKS (LONG)

#368021
OPTION
ALU SHOCK SPRING RETAINING COLLAR (4)

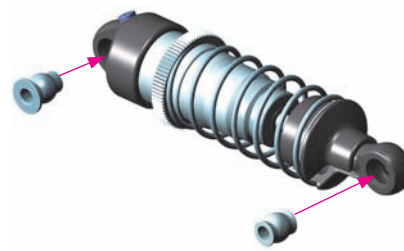

8. FINAL ASSEMBLY

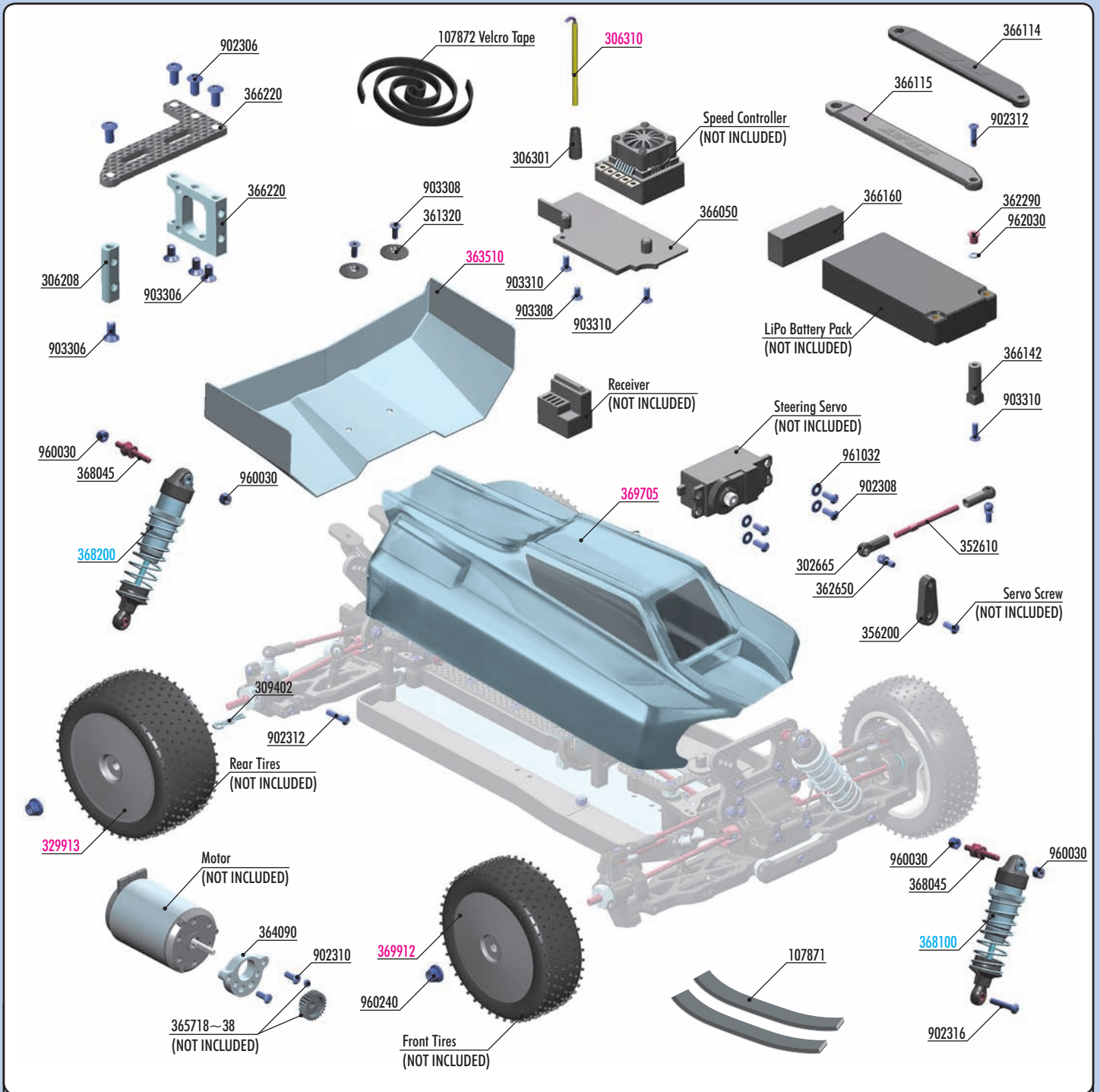

BAG

08

- 107871 HUDY SELF-ADHESIVE FOAM STRIP (2)
- 107872 VELCRO TAPE WITH DOUBLE SIDED TAPE 8x500MM
- 302665 COMPOSITE BALL JOINT 4.9MM - CLOSED WITH HOLE (4)
- 306208 ALU SERVO MOUNT - BOTH SIDES THREADED
- 306301 ANTENNA MOUNT - THIN
- 309402 BODY CLIP FOR 6MM BODY POST (4)
- 352610 ADJ. TURNBUCKLE M3 L/R 45 MM - SPRING STEEL™ (2)
- 356200 BRAKE/THROTTLE ARMS & STEERING SERVO ARMS - SET
- 361320 BODY MOUNT, BATTERY MOUNT - V2 & WING SHIM (2)
- 362290 STEEL STEERING BUSHING - SHORT (2)
- 362650 BALL END 4.9MM WITH THREAD 6MM (2)
- 364090 ALU ECCENTRIC MOTOR BULKHEAD INSERT - V3
- 365718~38 ALU PINION GEAR HARD COATED 18~38T/48 (OPTION)
- 366050 COMPOSITE RADIO PLATE - V2
- 366114 COMPOSITE BATTERY STRAP - LONG
- 366115 COMPOSITE BATTERY STRAP - LONG XL
- 366142 COMPOSITE BATTERY HOLDER STAND (2)
- 366160 FOAM SPACER FOR BATTERY
- 366220 INDEPENDENT SERVO MOUNT - V2 - SET
- 368045 STEEL SCREW SHOCK PIVOT BALL WITH HEX (2)

- 902306 HEX SCREW SH M3x6 (10)
- 902308 HEX SCREW SH M3x8 (10)
- 902310 HEX SCREW SH M3x10 (10)
- 902312 HEX SCREW SH M3x12 (10)
- 902316 HEX SCREW SH M3x16 (10)
- 903306 HEX SCREW SFH M3x6 (10)
- 903308 HEX SCREW SFH M3x8 (10)
- 903310 HEX SCREW SFH M3x10 (10)
- 960030 NUT M3 (10)
- 961032 WASHER S 3.2 (10)
- 962030 WASHER S 3x6x0.3 (10)
- 960240 NUT M4 WITH SERRATED FLANGE (10)

- 368100 FRONT SHOCK ABSORBERS COMPLETE SET (2)
- 368200 REAR SHOCK ABSORBERS COMPLETE SET (2)

- 306310 ANTENNA (2)
- 363510 LEXAN REAR WING (2)
- 369705 XRAY XB4 BODY
- 369912 FRONT WHEEL AERODISK WITH 12MM HEX - WHITE (2)
- 329913 REAR WHEEL AERODISK WITH 12MM HEX - WHITE (2)

8. FINAL ASSEMBLY

902316
SH M3x16

960030
N M3

INITIAL POSITION

902312
SH M3x12

960030
N M3

INITIAL POSITION

ALU NUTS M3

OPTION	ALU NUTS M3	OPTION
#296530-B	BLUE	OPTION
#296530-K	BLACK	OPTION
#296530-O	ORANGE	OPTION
#960031	SILVER	INCLUDED

SERVO LINK

Adjust servo link to fit your servo.

TIP Install the pivot balls with Professional Multi Tool (HUDY #183011)

902306
SH M3x6

902308
SH M3x8

961032
SHIM S 3.2

HUDY ALU SERVO HORNS

#293497	23T
#293498	24T
#293499	25T

HUDY CLAMP ALU SERVO HORNS

#293404	23T
#293405	24T
#293406	25T

For more in-corner steering and better steering response, aluminum servo horns may be used.

USE APPROPRIATE SERVO ARM:

(23T)

(24T)

(25T)

8. FINAL ASSEMBLY



903306
SFH M3x6

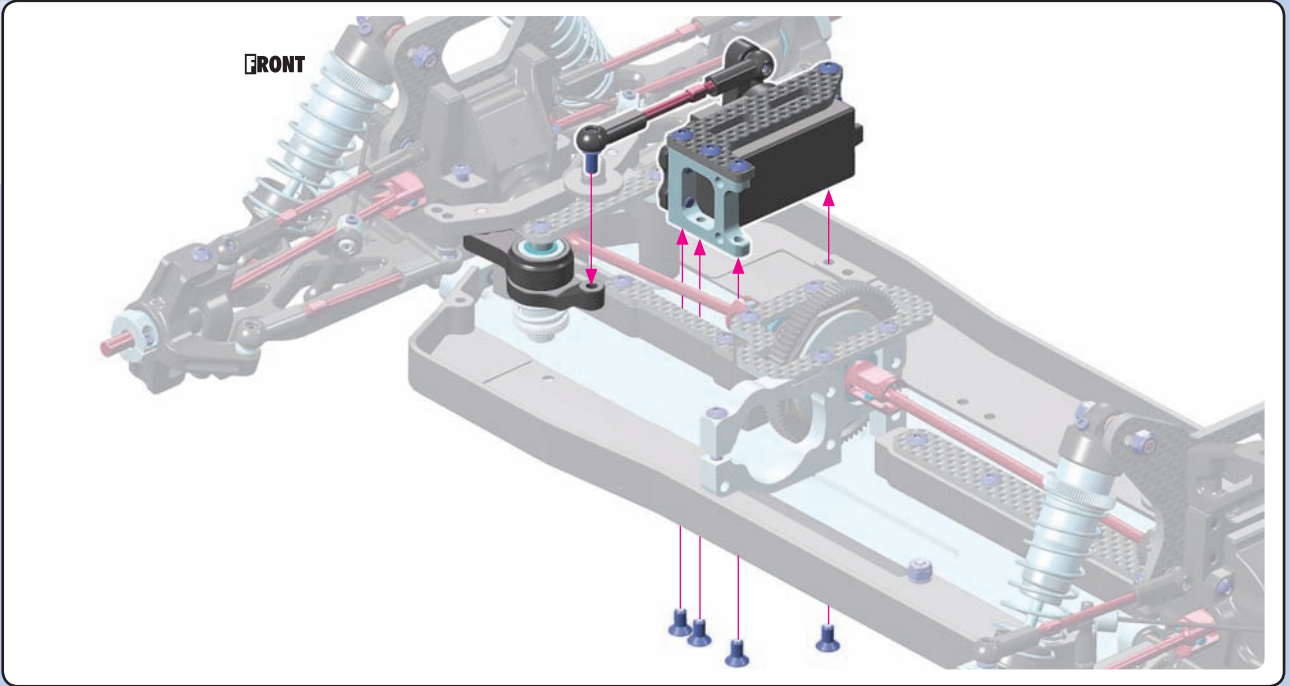

902310
SH M3x10

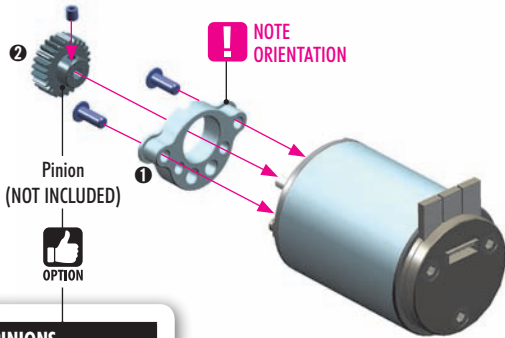

PINIONS	
#365718	18T / 48P
#365719	19T / 48P
#365720	20T / 48P
#365721	21T / 48P
#365722	22T / 48P
#365723	23T / 48P
#365724	24T / 48P
#365725	25T / 48P
#365726	26T / 48P
#365727	27T / 48P
#365728	28T / 48P
#365729	29T / 48P
#365730	30T / 48P
#365731	31T / 48P
#365732	32T / 48P
#365733	33T / 48P
#365734	34T / 48P
#365735	35T / 48P
#365736	36T / 48P
#365737	37T / 48P
#365738	38T / 48P

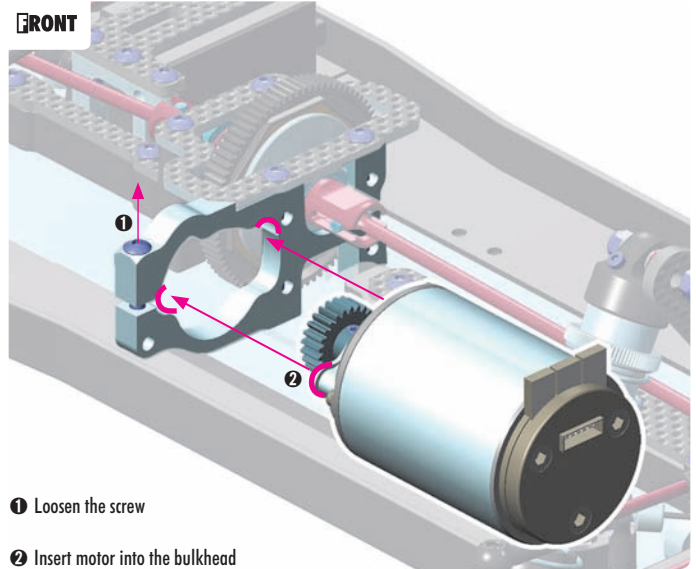

- ❶ Loosen the screw
- ❷ Insert motor into the bulkhead

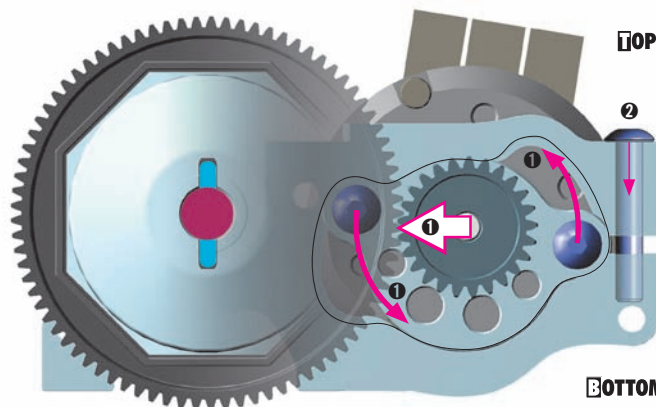

- ❶ Adjust gear mesh
- ❷ Tighten the screw

Adjust the motor so the pinion meshes with the spur gear properly. Make sure the gear mesh is not too tight. There should be a small amount of play between the teeth of the pinion gear and the spur gear.

8. FINAL ASSEMBLY



903308
SFH M3x8

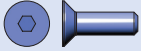

903310
SFH M3x10

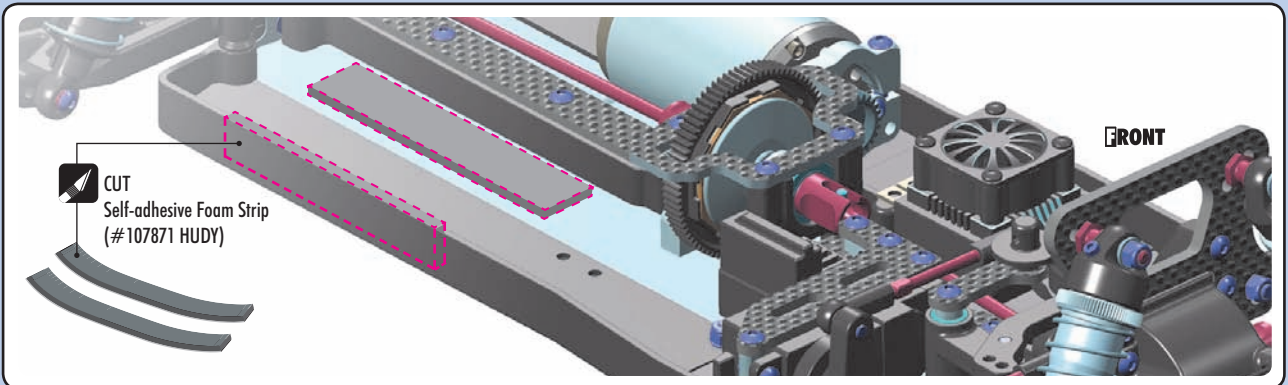
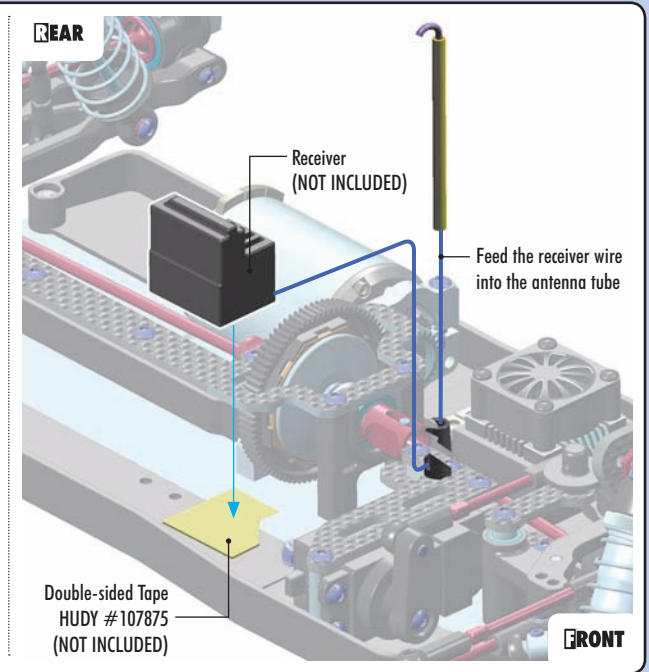
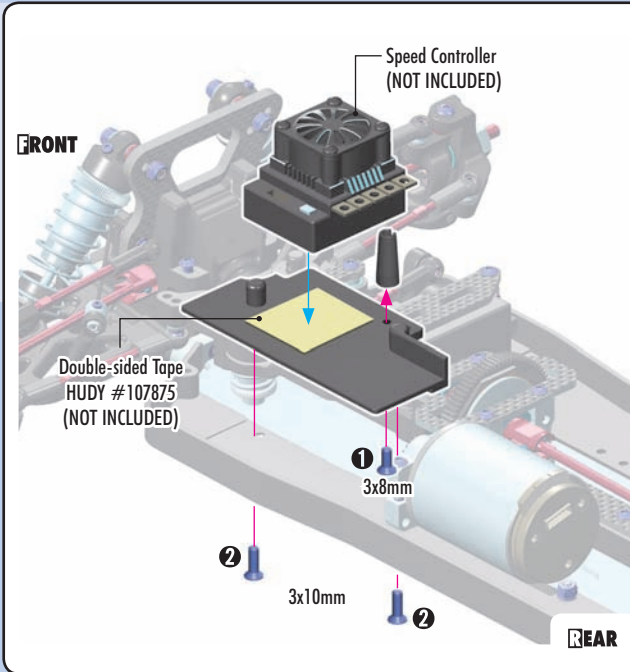

902312
SH M3x12



903310
SFH M3x10



962030
S 3x6x0.3

ALTERNATIVE 1

FORWARD WEIGHT BALANCE POSITION
(INITIAL SETTING)

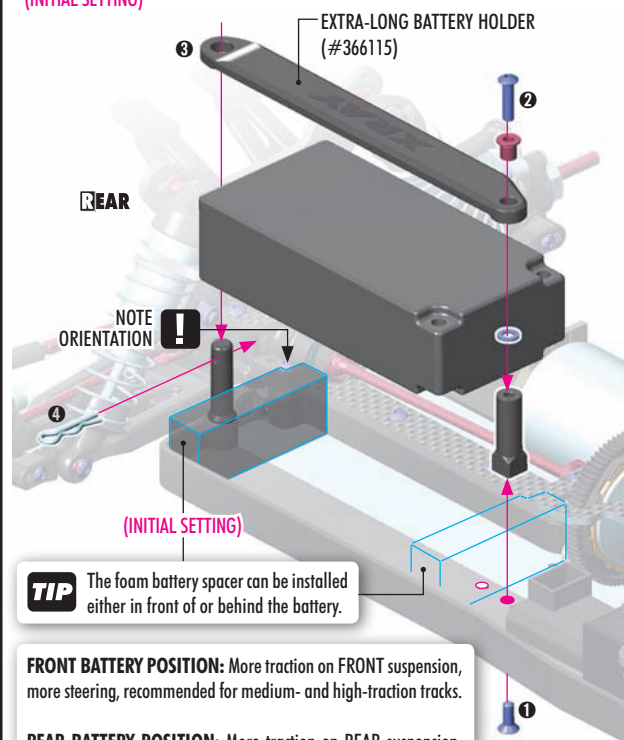

FRONT BATTERY POSITION: More traction on FRONT suspension, more steering, recommended for medium- and high-traction tracks.

REAR BATTERY POSITION: More traction on REAR suspension, more stable, recommended for medium- and low-traction tracks.

ALTERNATIVE 2

REARWARD WEIGHT BALANCE POSITION

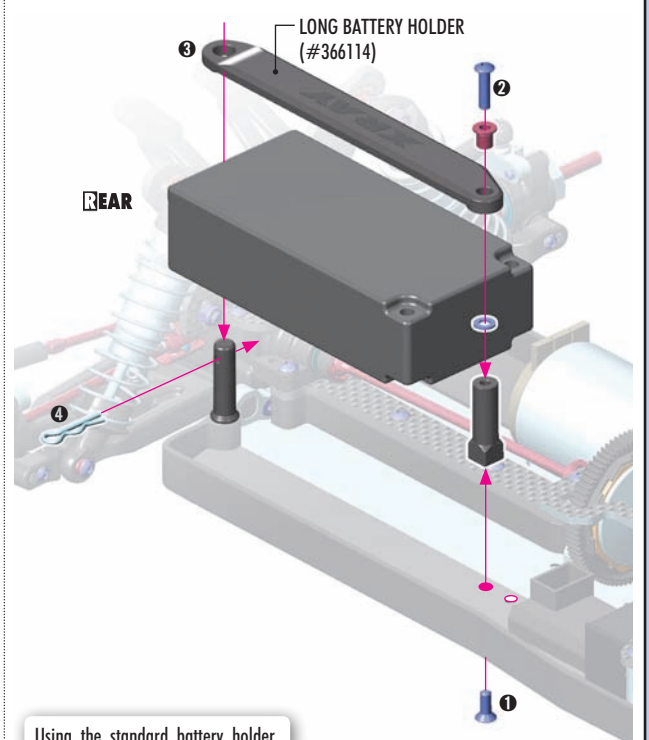

Using the standard battery holder positions the battery to the REAR.

8. FINAL ASSEMBLY

- 1 Before cutting and making holes on the BODY, put the unpainted body on the chassis to confirm the mounting position and location for holes and cutouts. Before cutting and making holes on the WING, put the unpainted wing on the wing holders to confirm the mounting position and location for holes and cutouts.
- 2 Before painting, wash the inside of the body with mild detergent, and then rinse and dry thoroughly.
- 3 Mask all windows.

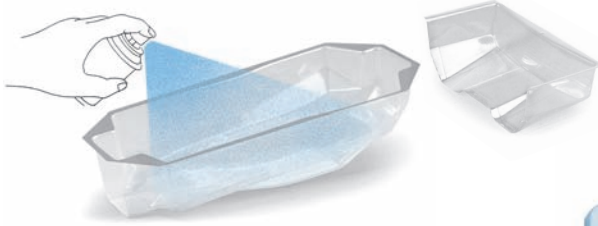

- 4 Apply paint masks as appropriate.
- 5 Paint the body using paints formulated for polycarbonate bodies.
- 6 When the paint is dry, remove the masking.
- 7 Carefully cut out the body using appropriate scissors or cutting tools.
- 8 When you have finished cutting, peel off the external protective films.

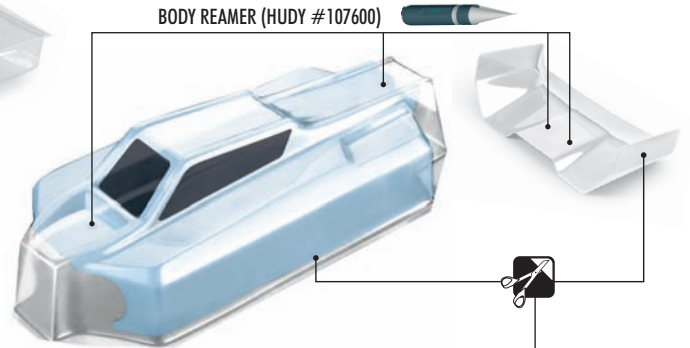

XRAY LEXAN BODY

#369703	0.75mm		OPTION
#369704	0.50mm		OPTION
#369705	0.75mm	ALPHA	INCLUDED
#369706	0.50mm	ALPHA	OPTION

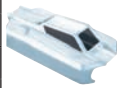

XRAY LEXAN REAR WING

#323510	1.0mm		OPTION
#323511	1.5mm		OPTION
#323513	1.0mm	RANK	OPTION
#323517	1.0mm	TEC	OPTION
#363510	1.0mm		INCLUDED
#363511	1.5mm		OPTION
#363512	2.0mm		OPTION



XRAY LEXAN CENTER FIN

#323515	1.0mm	ZAP	OPTION
---------	-------	-----	--------

WING CUTTING LINE OPTIONS

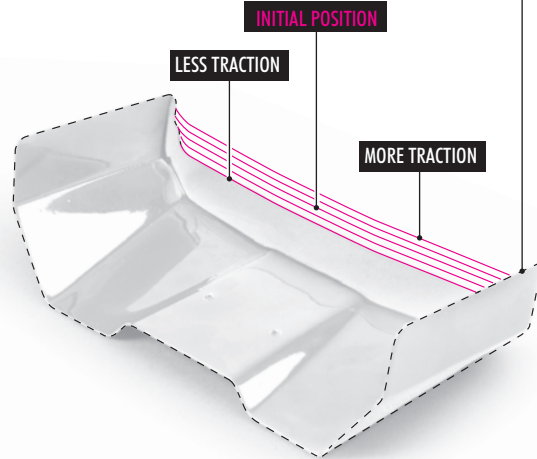

2x



Double-sided Velcro™ tape is used to seal the body against the side guards.

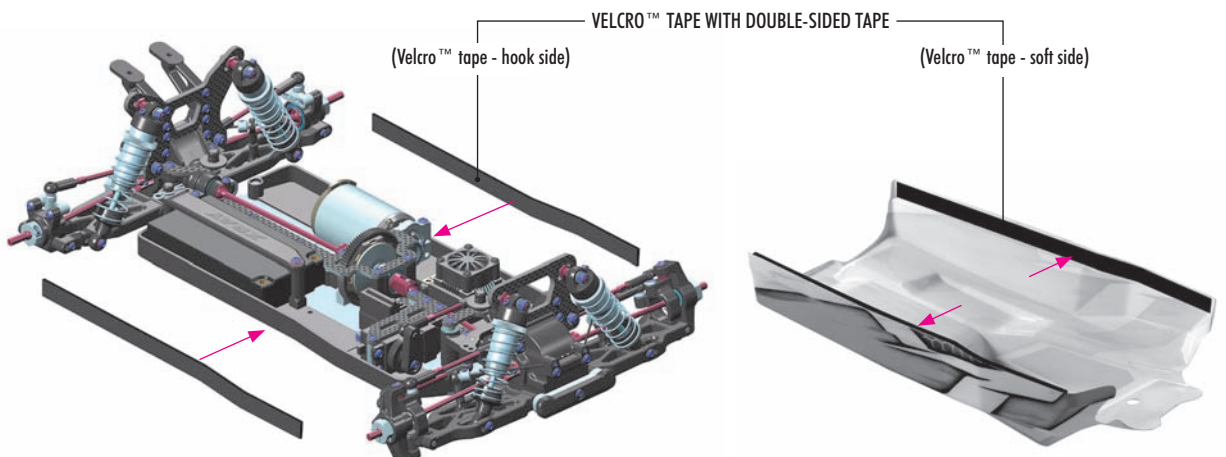

8. FINAL ASSEMBLY



960240
N M4

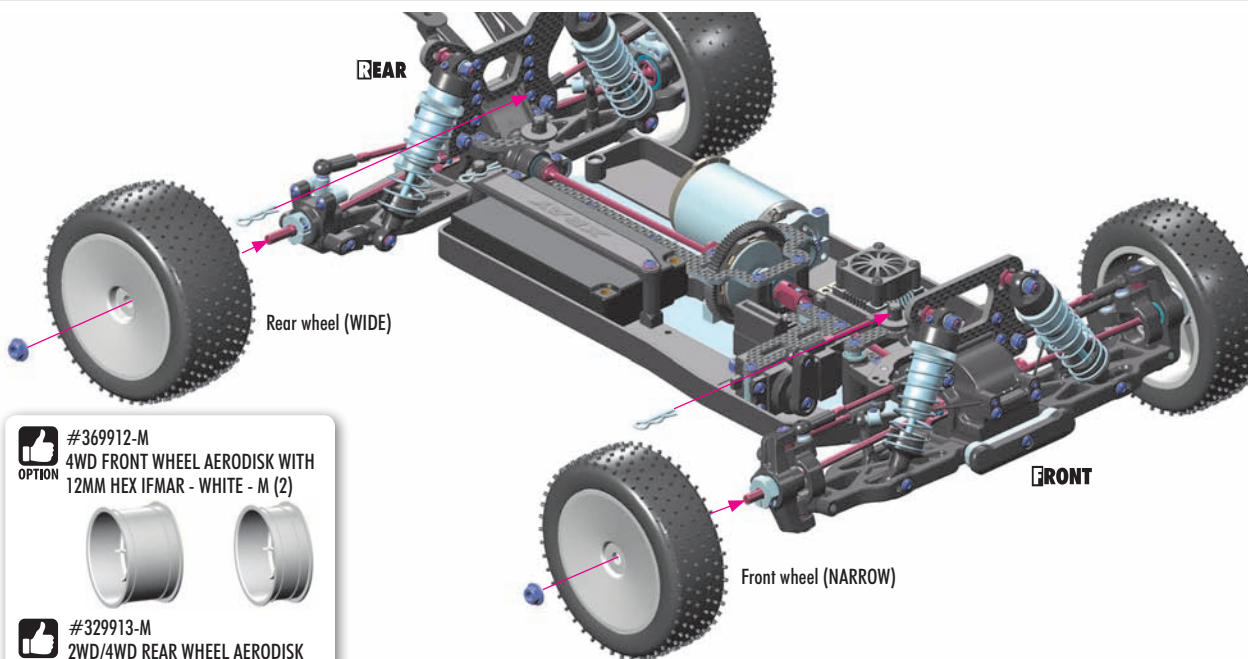

#369912-M
4WD FRONT WHEEL AERODISK WITH
12MM HEX IFMAR - WHITE - M (2)



#329913-M
2WD/4WD REAR WHEEL AERODISK
12MM HEX IFMAR - WHITE - M (2)



OPTIONAL ALU WING SHIM

#293561	SILVER	OPTION
#293561-0	ORANGE	OPTION



903308
SFH M3x8

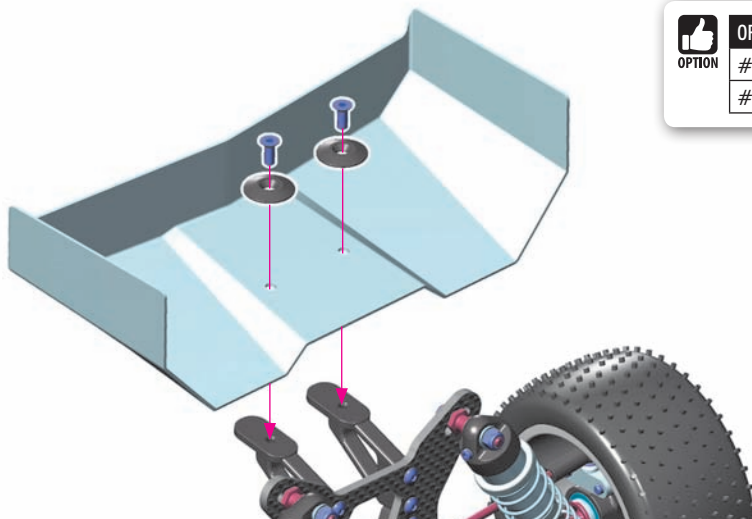

FINAL ASSEMBLY VIEW

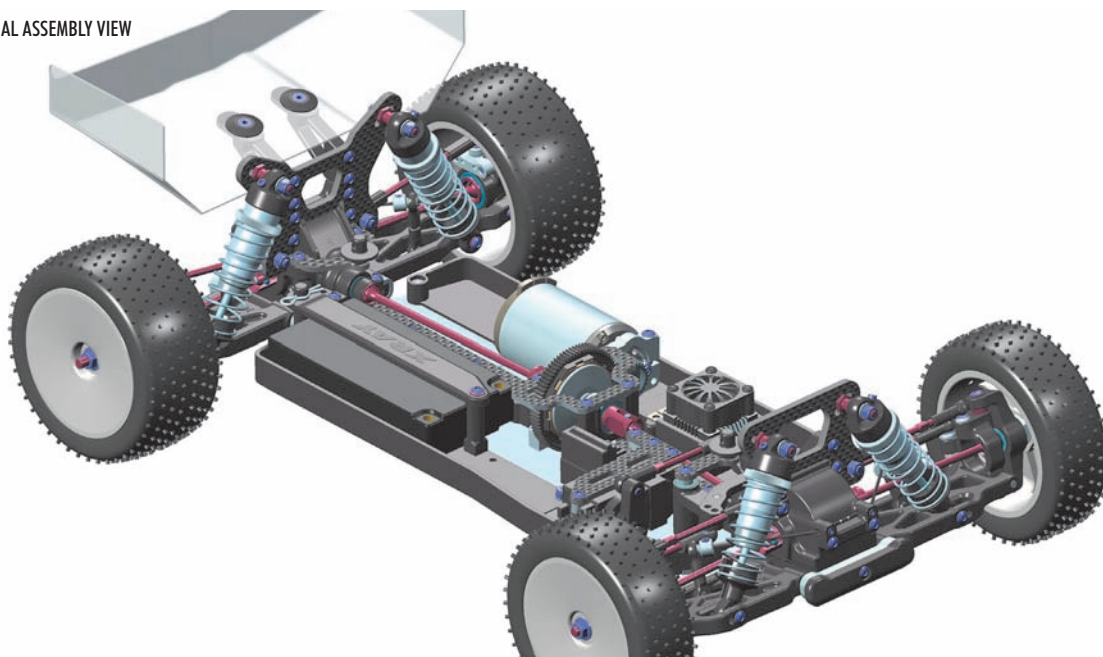

SHOCK MAINTENANCE

The most important maintenance task for keeping consistent shock performance is refilling and bleeding them correctly. If built correctly, it will not be necessary to re-build them often. Replacing warped/hard o-rings, scarred piston rods, or shaved/split/loose composite upper and lower ball joints are also important.

- For club racing, it is recommended to check the shocks for air inside before each race and only re-fill and bleed them if necessary. Before each race day, make sure you take the spring off of each shock, hold it up to your ear, and quickly compress the shock rod fully into the body while listening for any air making a "whistling" or "squishy" sound as it passes through the piston holes. If you hear any air, refill and bleed your shocks. For high-competition racing, it is recommended that the shocks be re-filled and bled before a large event.
- If building or pairing new shocks, always make sure they are the same length using a shock length measuring tool and adjust the lower ball joints as needed.
- During regular shock operation, oil naturally gets on the shock shaft and drop-by-drop slightly gets out of the shock body. Shocks should be inspected regularly after each race, and oil replaced as required.

BEARING MAINTENANCE

Ball-bearings in an off-road car must be properly maintained for smooth operation and long lifespan.

The XB4 ball-bearings are degreased and are lubricated with HUDY Bearing Oil or HUDY Grease. The following procedures are recommended to clean all of the bearings in your off-road car. For high-competition racing, we recommended doing this every 3-4 weeks, or before a major race.

- 1 Remove the seals on both sides of the bearing (if present). If the seals bend a little and you can see a kink, carefully flatten the kink out by hand.
- 2 Spray the seals with motor cleaner and blow dry with compressed air.
- 3 Spray the bearing on both sides with motor cleaner.
- 4 Spin the bearing while it is still wet to dislodge any particles with the cleaner.
- 5 Spray the bearing on both sides again.
- 6 Blow both sides of the bearing dry with compressed air to make sure particles come out.
- 7 Hold the inner part of the bearing with my left thumb/forefinger and spin it to make sure it spins free without any abnormal vibrations or sounds.
- 8 Place one drop of bearing oil into each side of the bearing.
- 9 Replace both seals at the same time by lining them up on each side of the bearing and lightly pressing them in all the way around the bearings circumference with your thumb and forefinger. Do not press too hard or use any type of tool, such as a wrench tip, to push the blue seals in as they will push in too far, bend and cause drag.

If you spin test the bearing after you have re-oiled and sealed it, it will not spin freely for an extended period of time. The lightest of oils may allow it to spin for 1-2 seconds. This is normal and once you have mounted the bearings in the car again, the drive train will spin freely.

Make sure you use a motor cleaner that does not leave a residue after it dries as this may cause drag and wear in the bearings.

RECOMMENDED PRODUCTS

- Use correct oil or grease to lubricate the bearings:
 #106230 HUDY Bearing Oil
 #106220 HUDY Bearing Grease - Standard
 #106221 HUDY Bearing Grease - Blue
 #106222 HUDY Bearing Grease - Red



SUSPENSION & DRIVETRAIN MAINTENANCE

- Check suspension for free movement during building and operation, and especially after running and if you have crashed the car. If the suspension does not move freely, use the appropriate HUDY Arm Reamer to clean and resize the holes of the suspension arms.
- Regularly check the drive shaft pins (both side and center) and if they show any wear must be immediately replaced by new pins. If the car is run with worn pins, excessive wear on the diff outdrives will result. The #106000 HUDY Drive Pin Replacement Tool (for 3mm Pins) is a compact, rugged multi-use tool set for replacing 3mm drive pins in drive shafts. Use the HUDY replacement drive shaft pins 3x12 (#106051).
- Regularly inspect and replace the connecting pins which connect the center drive shafts with the pinion gear, and also the pins that connect the wheel drive shafts with wheel axles. Use HUDY Graphite Grease to lubricate the drive shaft connecting joints and the diff gears.
- Pivot balls and ball-joints will naturally wear for some time and will generate play. If there is too much play the pivot balls and ball joints need to be replaced.
- If the car is run in wet conditions, apply WD-40® on all drivetrain parts before the run. After the run, clean and dry the parts again.



#106210 HUDY GRAPHITE GREASE or #106213 HUDY JOINT GREASE

HUDY SPRING STEEL™

The HUDY Spring Steel™ used in the car is the strongest and most durable steel material on the RC market. While items made from HUDY Spring Steel™ are still subject to wear, the lifespan is considerably longer than any other material. As parts made from HUDY Spring Steel™ wear, the

brown color will fade (get lighter) but it will not affect the strength of the material. The brown color is only a surface treatment and if the brown color will wear the durability of the part will be still strong.

RACE _____
 TRACK _____
 NAME _____ DATE _____

LAPS _____ BEST LAP TIME _____ sec
 QUALIFYING POSITION _____ FINAL POSITION _____

TRACK SIZE OPEN MEDIUM TIGHT
 TRACK TRACTION HIGH MEDIUM LOW
 TRACK SURFACE SMOOTH MEDIUM BUMPY
 TRACK TYPE HARD PACKED SOFT DIRT CLAY
 CARPET BLUE GROOVE ASTRO TURF GRASS
 TRACK CONDITION DRY DUSTY WET MUD

DIFFERENTIAL TYPE

FRONT ↓	MIDDLE ↓	REAR ↓
GEAR DIFF <input type="checkbox"/>	GEAR DIFF <input type="checkbox"/>	GEAR DIFF <input type="checkbox"/>
BALL DIFF <input type="checkbox"/>	SLIPPER <input type="checkbox"/>	BALL DIFF <input type="checkbox"/>
OIL _____ cst	OIL _____ cst	OIL _____ cst

SATELLITE GEARS

FRONT	MIDDLE	REAR
COMPOSITE <input type="checkbox"/>	COMPOSITE <input type="checkbox"/>	COMPOSITE <input type="checkbox"/>
STEEL <input type="checkbox"/>	STEEL <input type="checkbox"/>	STEEL <input type="checkbox"/>

CROWN GEAR 40T 41T **SLIPPER ADJUSTMENT** _____ mm **CROWN GEAR** 40T 41T

GEARING

PINION _____ T SPUR GEAR _____ T

SHOCKS

FRONT	SHOCKS	REAR
cst _____	SPRINGS	cst _____
% _____	OIL	% _____
	REBOUND	
	PISTONS	
<input type="checkbox"/> 2 HOLES	<input type="checkbox"/> ø1.2mm <input type="checkbox"/>	<input type="checkbox"/> 2 HOLES <input type="checkbox"/>
<input type="checkbox"/> 3 HOLES	<input type="checkbox"/> ø1.3mm <input type="checkbox"/>	<input type="checkbox"/> 3 HOLES <input type="checkbox"/>
<input type="checkbox"/> 6 HOLES	<input type="checkbox"/> ø1.4mm <input type="checkbox"/>	<input type="checkbox"/> 6 HOLES <input type="checkbox"/>
<input type="checkbox"/> _____ HOLES	<input type="checkbox"/> ø1.6mm <input type="checkbox"/>	<input type="checkbox"/> _____ HOLES <input type="checkbox"/>
	<input type="checkbox"/> ø1.7mm <input type="checkbox"/>	
	CUSTOM PISTONS	
	ø _____ mm ø _____ mm	

SHOCK TOWER

FRONT ALU GRAPHITE REAR GRAPHITE ALU

ANTI ROLL BAR

FRONT _____ mm THICKNESS _____ mm REAR _____ mm

TIRES

FRONT	TIRES	REAR
	BRAND	
	COMPOUND	
	INSERTS	
	WHEELS	

ELECTRONICS

MOTOR _____ SPEEDO _____
 MOTOR TIMING _____ BATTERY _____

ELECTRONICS LAYOUT

MOTOR POSITION FRONT REAR
 BATTERY POSITION FRONT REAR
 BATTERY SIZE STD. SHORT LOW SHORT

COMMENTS

APPLIED APPLIED

FRONT **REAR UPRIGHT**

STEERING BLOCK
 MEDIUM
 HARD
 GRAPHITE

SHIM _____ mm

DRIVE SHAFT
 CVD ECS
 Length _____ /mm

LONGER BUSHINGS
 UP
 DOWN

LOWER SHOCK POSITION

DOWNSTOP _____ mm

DRIVE SHAFT Length _____ /mm

SHIM _____ mm

HARD GRAPHITE ALU

ROLL ENTER

DOWNSTOP _____ mm

#107711 GAUGE

HUDBY #107701 SUPPORT BLOCKS

CASTER
 6°
 9°
 12°

CASTER BLOCK
 MEDIUM
 HARD
 GRAPHITE
 ALU

SHOCK TOWER POSITION
 FRONT REAR

SHOCK POSITION
 FRONT REAR

UPRIGHT WHEELBASE
 SHIM _____ /mm

IN FRONT OF ARM

OFFSET _____ /slots

RAISING GEARBOX
 YES NO

BUMP STEER SHIM _____ mm

FRONT

ROLL CENTER
 1° 0.5°
 ECCENTRIC BUSHINGS

FF **RF** **RR**

RR3° 1-DOT YES NO

RR1°

ALU BRASS

ALU BRASS

FRONT TOE **OUT**

ARM SHIM _____ mm

ALU STEERING PLATE #362573

UPPER PLATE
 STANDARD
 STEERING BRACE

STEER. PLATE
 HARD
 GRAPHITE
 ALU

BUMP STEER
 SHIM _____ mm
 SHIM UNDER STEER. PLATE

SERVO SAVER
 SOFT
 MEDIUM
 TIGHT

MATERIAL
 STANDARD
 GRAPHITE

REAR TOE **IN**

GRAPHITE FOR REAR BRACE
 YES
 NO

REAR BRACE
 MEDIUM
 HARD

ARM SHIM _____ mm

FRONT **REAR**

FRONT CAMBER _____ °

FRONT ARMS
 LONG SHORT
 MEDIUM
 HARD
 GRAPHITE

REAR ARMS
 LONG SHORT
 MEDIUM
 HARD
 GRAPHITE

REAR CAMBER _____ °

DOWNSTOP SHIM _____ mm

LENGTH _____ mm

UPSTOP SHIM _____ mm

RIDE HEIGHT _____ mm

RIDE HEIGHT _____ mm

#107720 GAUGE

BODY
 STANDARD
 LIGHT

BALANCE _____ g

CHASSIS
 STANDARD
 2.5mm

BALANCE _____ g

BALANCE _____ g

WING THICKNESS
 1.0mm 1.5mm 2.0mm

WING CUTTING LINE **SIDE LINE**
 1 2 3 4 5
 HIGHER LOWER

CHASSIS FLEX
 SCREW USED
 SCREW NOT USED

SIDE GUARDS
 MEDIUM
 HARD

BALANCE _____ g

FRONT **REAR**

EXCLUSIVE PROFESSIONAL

HUDY

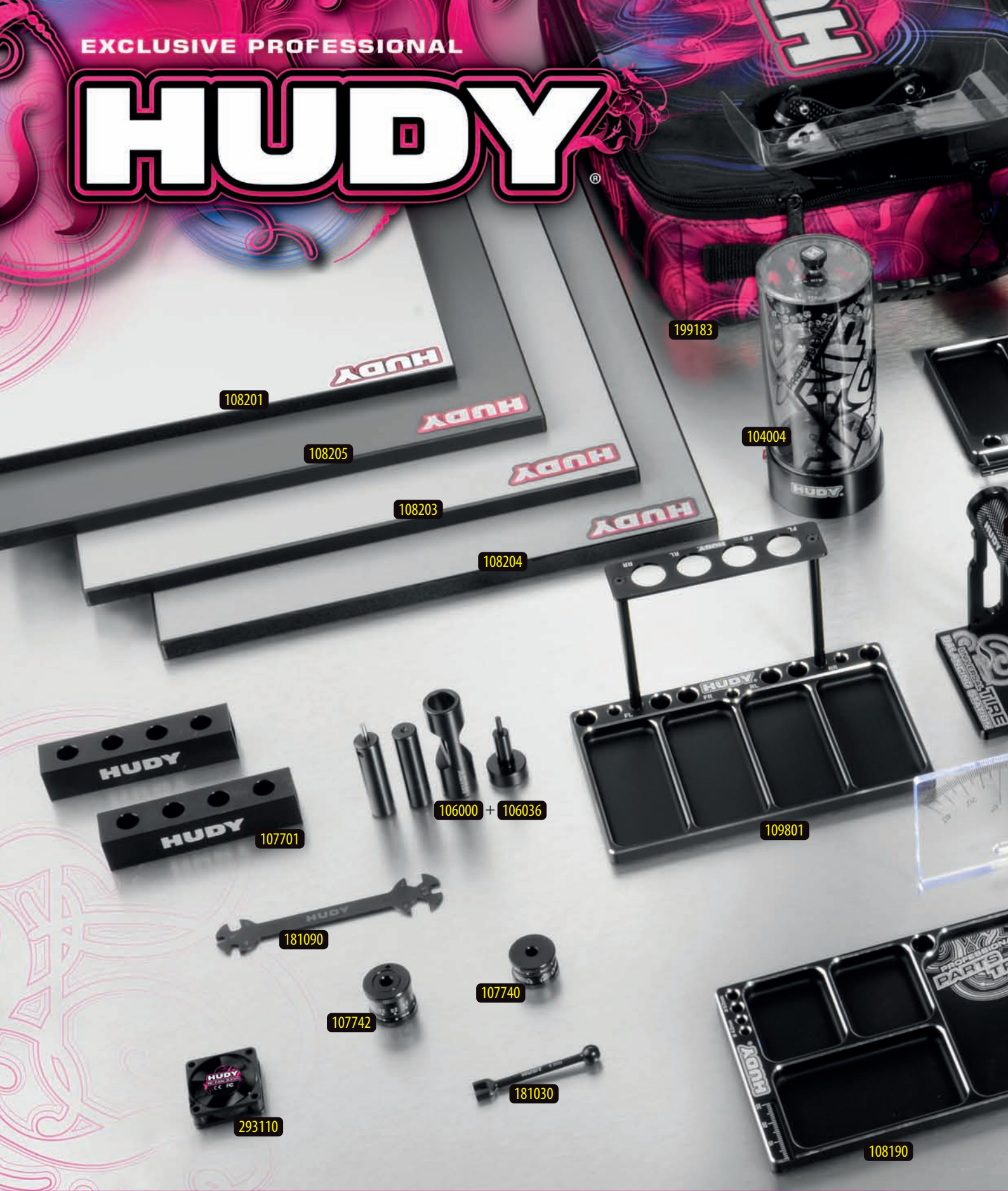

- 104004 HUDY AIR VAC - VACUUM PUMP - 1/10 OFF-ROAD
- 105500 HUDY UNIVERSAL TIRE BALANCING STATION
- 105520 WHEEL ADAPTER FOR 1/10 TOURING CARS - 12MM
- 106000 HUDY DRIVE PIN REPLACEMENT TOOL (FOR 3MM PINS)
- 106036 EJECTOR PIVOT PIN & ALTERNATING PIVOT 2.5MM FOR #106000
- 107090 HUDY BEARING CHECKING TOOL
- 107601 LIMITED EDITION - REAMER FOR BODY 0-9MM + COVER - SMALL
- 107701 CHASSIS DROOP GAUGE SUPPORT BLOCKS 20MM FOR 1/8 - LW(2)
- 107740 HUDY ADJUSTABLE RIDE HEIGHT GAUGE 14-20MM
- 107742 HUDY ADJUSTABLE RIDE HEIGHT GAUGE 20-30MM
- 107855 HUDY PIT LED
- 107880 CHASSIS BALANCING TOOL (2)

- 108160 HUDY 1/10 OFF-ROAD CAR STAND - V2
- 108190 HUDY ALU TRAY FOR PARTS
- 108201 FLAT SET-UP BOARD FOR 1/10 TOURING CARS
- 108203 FLAT SET-UP BOARD FOR 1/10 TOURING CARS - SILVER GREY
- 108204 FLAT SET-UP BOARD FOR 1/10 TOURING CARS - TITAN
- 108205 FLAT SET-UP BOARD FOR 1/10 TOURING CARS - DARK GREY
- 108905 UNIVERSAL EXCLUSIVE SET-UP SYSTEM FOR 1/10 OFF-ROAD CARS
- 108960 ALU NUT FOR 1/10 OFF-ROAD SET-UP SYSTEM (4)
- 109801 HUDY ALU TRAY FOR 1/10 OFF-ROAD DIFF & SHOCKS
- 109840 HUDY ALU TRAY FOR 1/10 OFF-ROAD DIFF ASSEMBLY
- 109860 HUDY ALU TRAY FOR SET-UP SYSTEM
- 109880 HUDY ALU TRAY FOR ACCESSORIES & PIT LED



111545 LIMITED EDITION - ALLEN WRENCH # 1.5MM
 112045 LIMITED EDITION - ALLEN WRENCH # 2.0MM
 132045 LIMITED EDITION - ALLEN WRENCH + BALL REPL. TIP # 2.0MM
 153055 LIMITED EDITION - SLOTTED SCREWDRIVER # 3.0MM - LONG
 175535 LIMITED EDITION - SOCKET DRIVER # 5.5MM
 177035 LIMITED EDITION - SOCKET DRIVER # 7.0MM
 181030 HUDY SPRING STEEL TURNBUCKLE WRENCH 3 MM
 181090 HUDY SPECIAL TOOL FOR TURNBUCKLES & NUTS
 183011 HUDY PROFESSIONAL MULTI TOOL
 188990 HUDY PROFESSIONAL BODY SCISSORS
 199060 HUDY ALU TOOL STAND
 199183 HUDY CAR BAG - 1/10 OFF-ROAD

199270 HUDY LIPO SAFETY BAG
 293110 HUDY BRUSHLESS RC FAN 30MM
 298100 HUDY TIN ROUND BOX 80X30MM
 293110XL HUDY BRUSHLESS RC FAN 30MM - SET OF 12PCS

For more information about tools, set-up equipment and accessories suitable for your car please visit:

www.hudy.net



www.teamxray.com

XRAY EUROPE

XRAY, K VÝSTAVISKU 6992, 91101 TRENCIN, SLOVAKIA, EUROPE
PHONE: +421-32-740 11 00, FAX: +421-32-740 11 09, info@teamxray.com

XRAY USA

RC AMERICA, 2030 Century Center Blvd #15, Irving, TX 75062, USA
PHONE: 214-744-2400, FAX: 214-744-2401, xray@rcamerica.com



[/TeamXray](#)



[/TeamXray](#)



[/TeamXray](#)



[/TeamXrayRC](#)



[/XrayRacing](#)



[/XrayRacing](#)