

# HUDY

**ULTIMATE**

**BREAK-IN BENCH**

FOR ALL 1/8 & 1/10 NITRO ENGINES

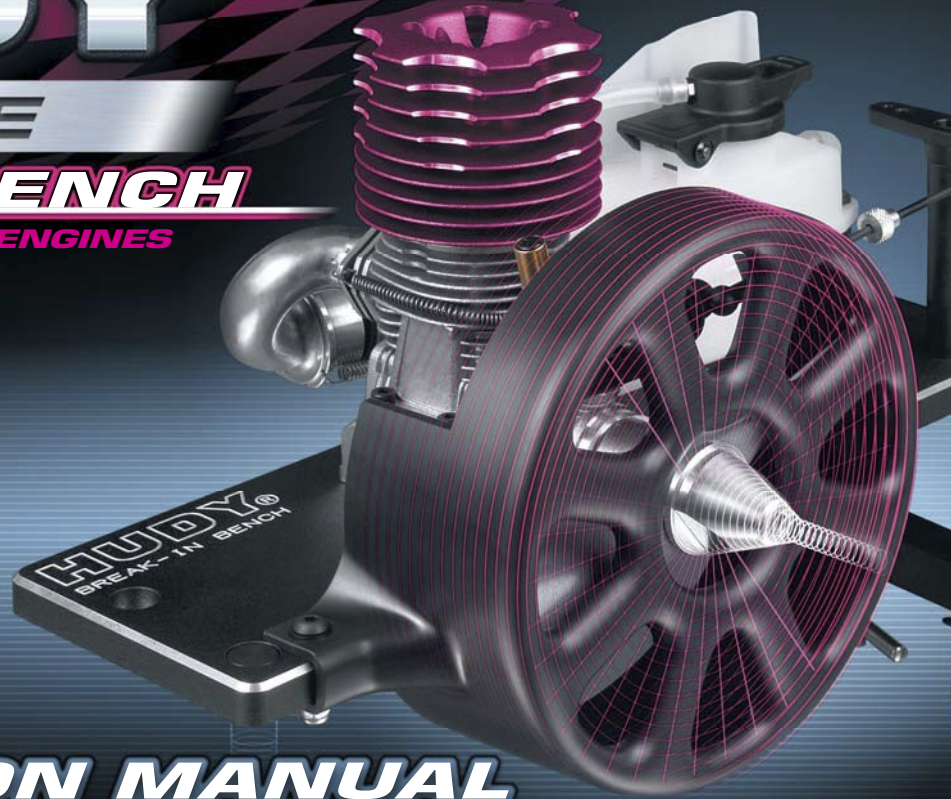

**INSTRUCTION MANUAL**

## CONTENTS

<b>INTRODUCTION.....</b>	<b>2</b>
<b>SAFETYFIRST.....</b>	<b>3</b>
<b>EXPLODEDVIEW.....</b>	<b>4</b>
<b>EQUIPMENTREQUIREDFOROPERATION.....</b>	<b>5</b>
<b>FACTORYPRE-ASSEMBLED.....</b>	<b>7</b>
<b>ASSEMBLY.....</b>	<b>8</b>
<b>PREPARATION.....</b>	<b>11</b>
<b>STARTINGTHEENGINE.....</b>	<b>13</b>
<b>BREAK-INPROCESS.....</b>	<b>15</b>
<b>TROUBLESHOOTING.....</b>	<b>17</b>
<b>WARRANTY.....</b>	<b>18</b>

## HUDY Engine Break-In Bench

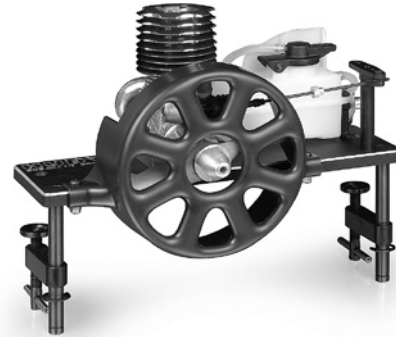

*The HUDY Engine Break-In Bench is the ultimate tool for easy, safe, and professional break-in of your .12/.15/.21ci engine (with 5mm extended crankshaft). It allows for a controlled break-in process that reduces wear & tear on engine components, ensuring increased performance, reliability, and longevity.*

*Constructed of top-quality components of tough aluminium and spring steel, the Engine Break-In Bench comes partially assembled from the factory to get you running sooner.*

*The heavy-duty aluminum base plate with integrated clamps provides quick, solid mounting on any workbench, and a large protective shroud safely covers the spinning propeller. Other features include a large-capacity 125cc fuel tank, pre-assembled throttle linkage, universal engine mounts, and special propeller. Break in your engine like the pros!*

## SAFETY FIRST

*The HUDY Engine Break-In Bench is **NOT A TOY**, it is a precision-manufactured hardware tool; if used improperly it can injure you or others nearby and/or cause damage to property or your nitro engine. It is very important to pay attention as indicated in this manual. Improper use of the tool can be very dangerous.*

*You alone are responsible for operating this tool and your nitro engine safely; act with discretion and pay special attention at all times.*

- *Carefully read and fully understand the safety instructions and engine operation instructions before you operate this tool or your engine.*
- *Keep these manuals in a place so you know where they are at all times.*
- *Follow the instructions carefully.*

**Running an engine on the Break-in Bench is extremely noisy and poses great hazards. Always follow these safety precautions:**

- *Wear safety glasses, ear protectors, and gloves.*
- ***DO NOT** wear a necktie, loose sleeves, or other loose clothes while using the unit. In case of long hair, wear your hair under a hat.*
- *Before starting the engine, always check that the engine is securely mounted.*
- *Keep clear of the propeller safety cover; never stick your fingers or anything else through the safety cover.*
- *Use the unit outside or in a well-ventilated room.*
- *When running the engine indoor, make sure the exhaust gasses are directed to outdoors. Stay away from the exhaust gasses at all times.*
- *Start the engine only using the spinner driver and an electric starting device (such as an electric drill).*
- *Avoid making engine adjustments while the engine is running.*
- *Stop the engine by pinching the fuel line.*
- *Avoid touching the cylinder head or the exhaust pipe as this may cause serious burns.*

# EXPLODED VIEW

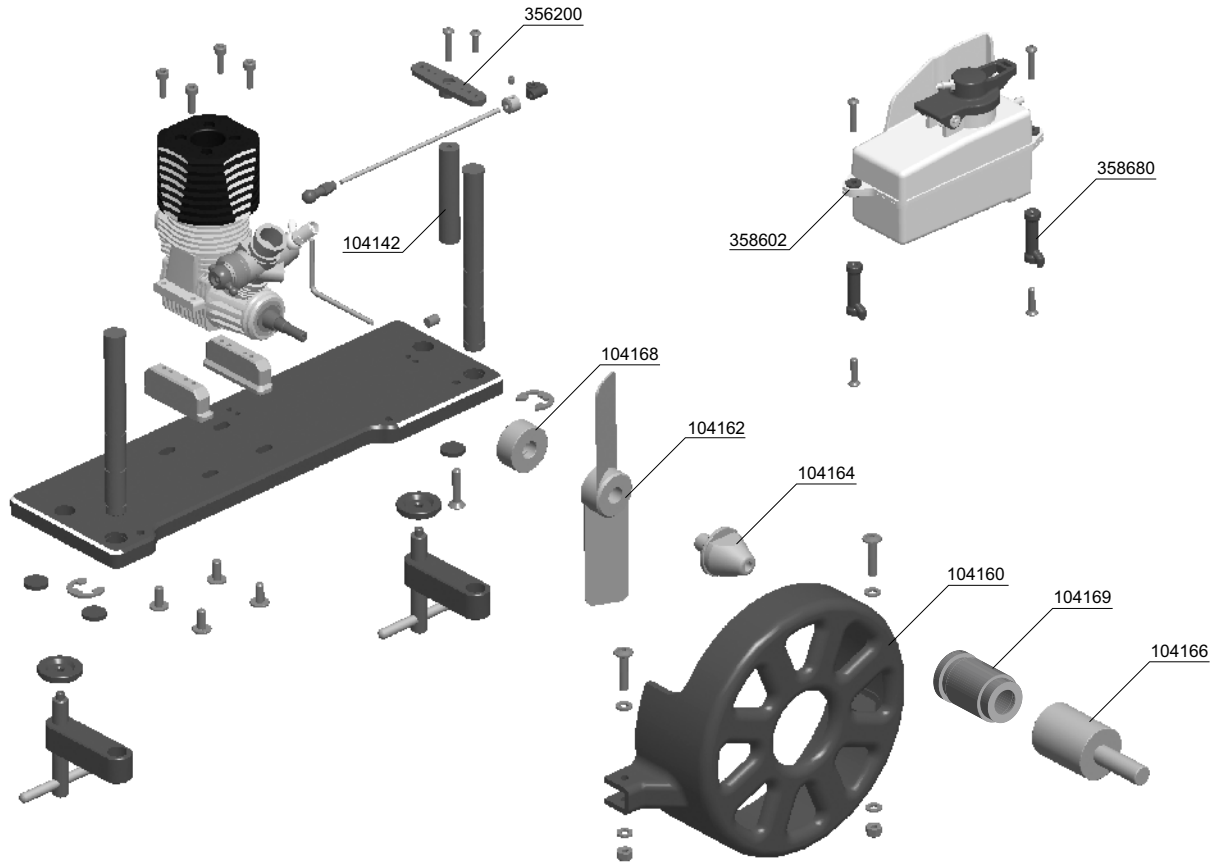

## EQUIPMENT REQUIRED FOR OPERATION

### ENGINE



*The HUDY Engine Break-In Bench is designed for use with all .12/.15/.21ci nitro engines with a 5mm extended crankshaft. The tapered crankshaft cone that was included with the engine must be used.*

### FUEL



*When breaking in your engine, we strongly recommend using the same fuel that you plan to run in your engine after break-in.*

### AIR FILTER



*Normally, you should always run your engine with an air filter.*

*However, an air filter is not used during the break-in process on the HUDY Engine Break-In Bench.*

### EXHAUST SYSTEM



*Use a compatible, high-quality exhaust system when breaking in your engine. Be sure to use all gaskets, springs, and other required mounting hardware.*

### GLOWPLUG STARTER



*A glowplug starter is required to ignite the glowplug for starting. We recommend using a high-quality, battery-operated glowplug starter from a reputable manufacturer.*

### GLOWPLUG WRENCH



*A glowplug wrench is required for removing/installing the engine glowplug. We recommend using a high-quality glowplug wrench such as the #107581 HUDY Wrench-Glowplug / Clutchnut.*

## SCREWDRIVER



*A high-quality screwdriver is required for adjusting the carburetor. We recommend using high-quality tools such as those offered by HUDY.*

## ALLEN WRENCHES



*High-quality Allen wrenches (2.0mm and 2.5mm) are required for assembling and adjusting the HUDY Engine Break-In Bench. We recommend using high-quality tools such as those offered by HUDY.*

## CRANKSHAFT OR PISTON LOCKING TOOL



*A crankshaft or piston locking tool is strongly recommended for preventing the crankshaft from turning while installing and tightening the propeller and spinner. We recommend using a locking tool from a reputable manufacturer.*

## 17MM WRENCH



*A 17mm wrench is required for tightening the spinner on the crankshaft. We recommend using tools from reputable manufacturers.*

## ELECTRIC DRILL



*An electric drill is required to spin the crankshaft to start the engine. We recommend using tools from reputable manufacturers.*

## TEMPERATURE GAUGE (OPTIONAL)



*A temperature gauge is useful to check the engine temperature during the break-in period.*

### HAIRDRYER OR HEAT GUN (OPTIONAL)



*A hairdryer or heat gun is recommended to pre-heat the engine prior to initial starting.*

### FOIL TAPE (OPTIONAL)



*Self-adhesive foil tape is recommended to cover the engine head fins to prevent overcooling during break-in.*

### PLIERS



*A pair of pliers is required to connect the throttle control rod ball-joint to the carburetor. We recommend using a pair of needle-nose pliers from a reputable manufacturer.*

## FACTORY PRE-ASSEMBLED

*The HUDY Engine Break-in Bench is pre-assembled at the factory with the exception of the fuel tank and stands, which must be installed before use. Attach the two plastic support stands to the base plate using the included flat-head screws, then attach the fuel tank to the stands using the two button head screws and rubber grommets.*

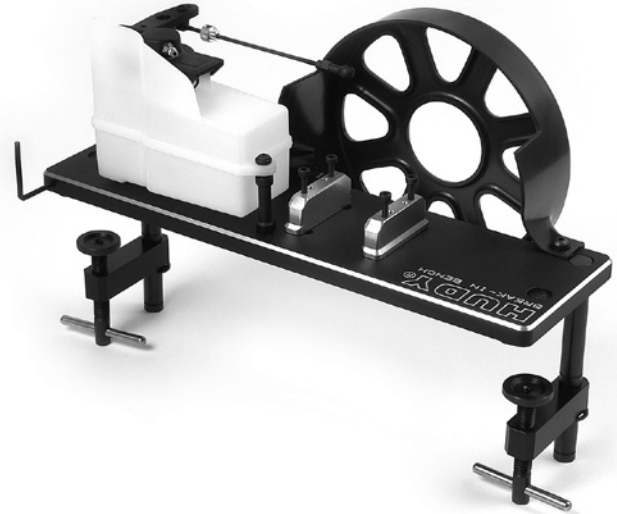

## ASSEMBLY

### SETTING THE ENGINE MOUNTS

1. Remove the engine mounts from the base plate.
2. Attach the engine mounts to the engine using the supplied M3x12 screws.

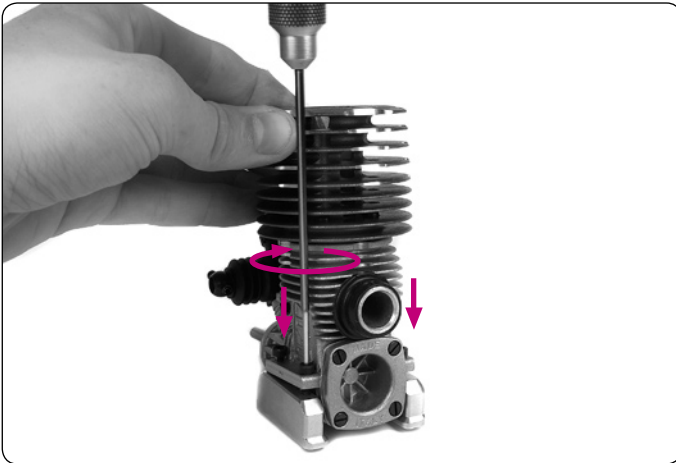

### ATTACH THE PROPELLER

1. Use a crankshaft or piston locking tool to prevent the crankshaft from rotating. This may require the removal of the crankcase rear plate or glowplug, respectively.
2. Slide the tapered flywheel cone onto the crankshaft.
3. Slide the propeller support plate onto the crankshaft. The small raised ridge on the support plate goes **TOWARD** the engine.

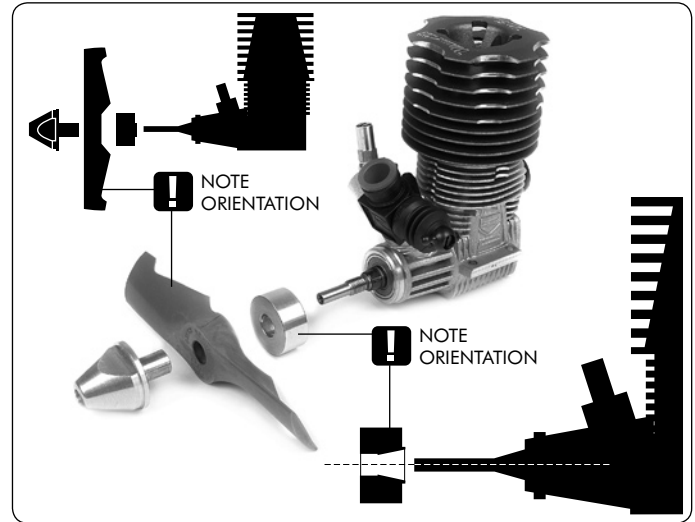

4. Slide the propeller onto the crankshaft. The smooth edge of the propeller goes **AWAY** from the engine.



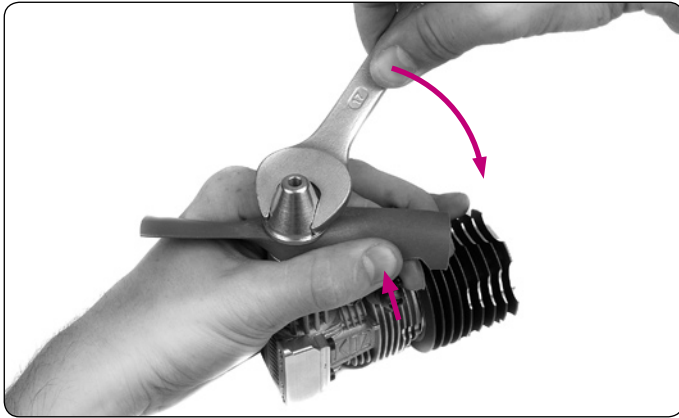

- 5. Thread the spinner onto the crankshaft, and tighten with a 17mm wrench until tight.**
- 6. Remove the crankshaft or piston locking tool (if used), and replace the crankcase rear cover or glowplug as appropriate.**
- 7. Rotate the propeller to ensure it does not touch hit the carb. If it touches the carb, remove the propeller, add a shim behind the tapered cone, then re-install the propeller.**

## MOUNTING THE ENGINE

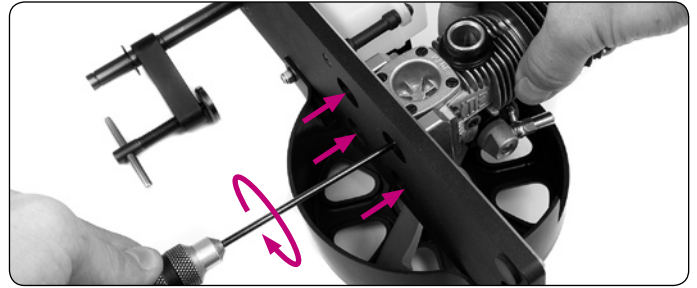

- 1. Re-attach the engine mounts to the base plate, and align the engine so the spinner is centered in the safety cover. Tighten the bottom engine mount screws.the engine position if necessary.**

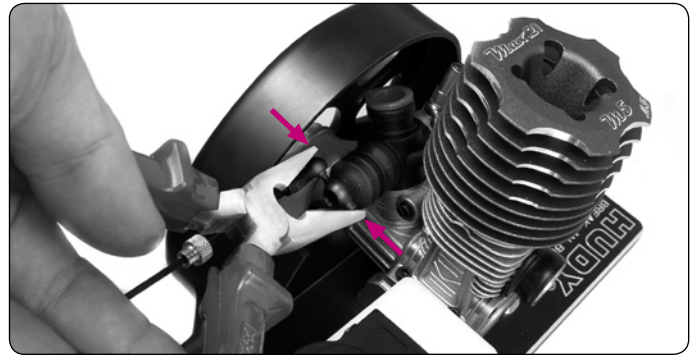

- 2. Attach the throttle control ball-joint to the carburetor.**

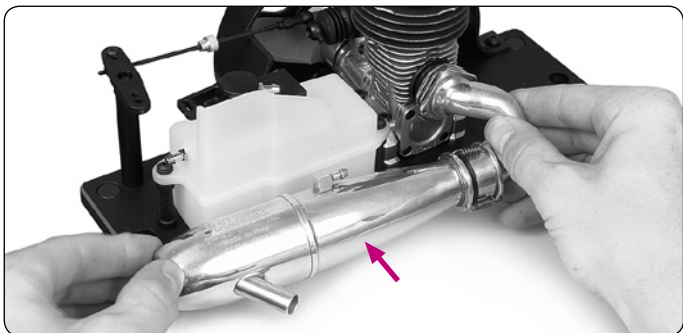

**3. Attach the exhaust pipe header to the engine exhaust outlet; remember to use the proper gasket and springs. Attach the pipe to the exhaust mounting wire and tighten the setscrew securely.**

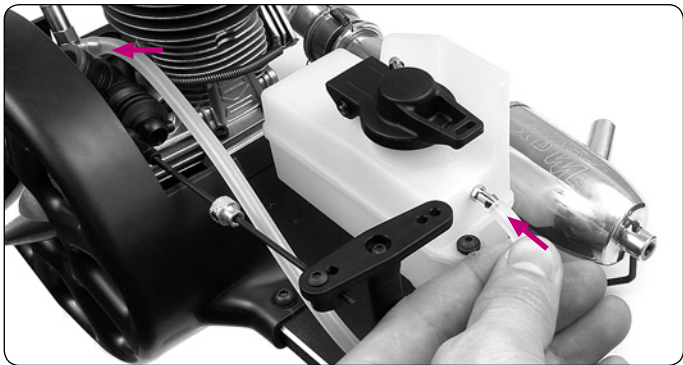

**4. Use a length of silicone fuel tubing to connect the fuel tank to the carburetor inlet.**

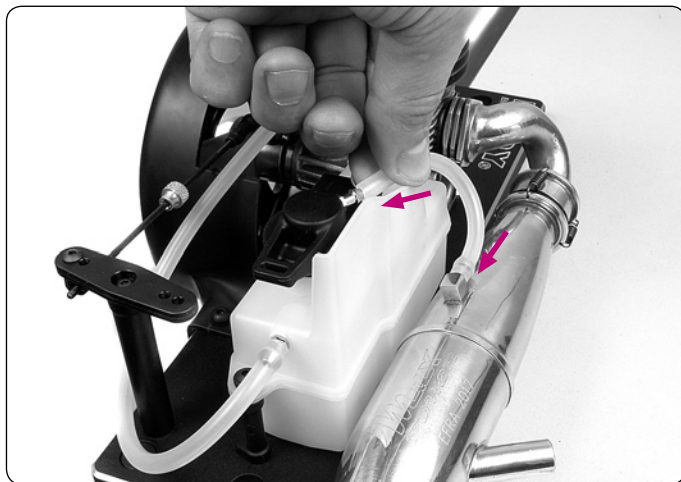

**5. Use a length of silicone fuel tubing to connect the exhaust pipe pressure fitting to the fuel tank cap pressure fitting.**

## MOUNTING THE BENCH

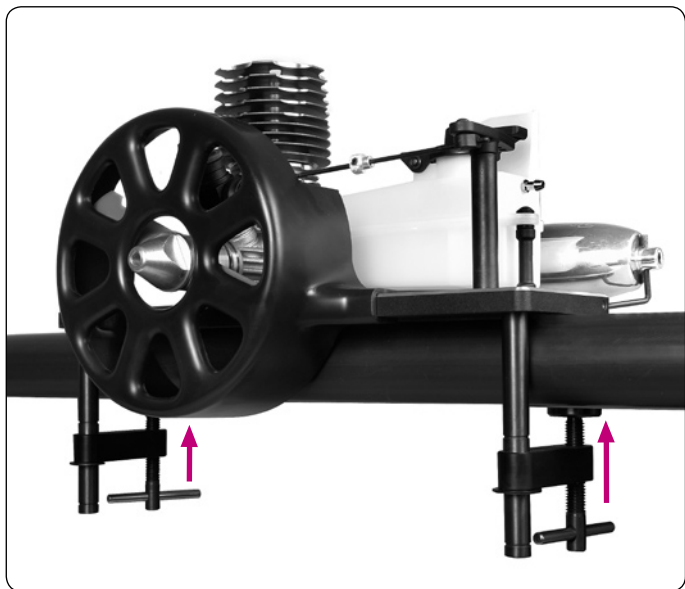

1. Place the bench on a solid platform (such as a work table).
2. Slide each clamp upward until the pad touches the underside of the table.
3. Tighten each pad securely.

## PREPARATION

*This section describes steps to take to prepare for engine break-in.*

### FUEL TUBING FREE FROM CUTS AND LEAKS

*Cuts in the fuel tubing will cause fuel leaks and make the engine run too lean.*

### CLEAR AREA AROUND BREAK-IN BENCH

*Since an air filter is not used during break-in on the bench, any swirling dirt that gets into the carb may cause internal engine damage.*

### ALL PARTS SECURELY ATTACHED AND TIGHTENED

*There will be a lot of vibration when the engine is running. Loose parts may become undone and cause personal injury or damage to the engine. The engine should be tightly attached to the engine mounts, and the engine mounts tightly attached to the bench.*

### CARBURETOR CINCH BOLT IS TIGHT

*Make sure the carburetor cinch bolt is tight. A loose carburetor may twist during engine operation, possibly coming into contact with the spinning propeller. This may cause personal injury or severe engine damage.*

### THROTTLE CONTROL MECHANISM IS TIGHT

*Make sure the throttle control mechanism is not too loose; it should remain in its set position and not move freely.*

### COVER ENGINE FINS WITH FOIL TAPE

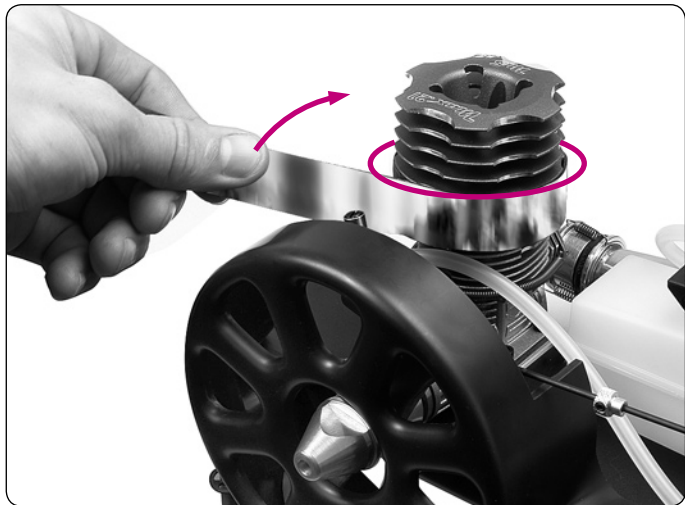

*Cover most of the engine head lower fins with self-adhesive foil tape to prevent over-cooling during break-in. The propeller directs a lot of cooling air across the engine head; if the head remains too cold during break-in, this will cause premature engine wear (just like an overly rich carb setting during break-in).*

### PRE-HEAT THE ENGINE

*Before starting the engine for the first time, pre-heat the engine head with a hairdryer or heat gun. This expands the sleeve slightly, allows for easier starting, and prevents excessive wear that a cold engine is subject to. If you use a heat gun, use the lower temperature setting; **DO NOT** use the higher temperature range as this may be too hot. Do not direct the hairdryer or heat gun at O-rings or other rubber or plastic parts.*



## STARTING THE ENGINE

*This section describes how to properly start the engine on the bench, and some safety precautions to take.*

### SAFETY INFORMATION – STARTING THE ENGINE

*Running an engine with a propeller represents great hazards. Always follow these safety precautions:*

- *Wear safety glasses, ear protectors and gloves.*
- *Don't wear a tie, loose sleeves or other loose textile while using the unit. In case of long hair, wear your hair under a hat.*
- *Before starting the engine, always check the mounting of the unit to the platform.*
- *ONLY use the unit outside or in a well-ventilated room.*
- *When running the engine indoors, make sure the exhaust gases are directed to outdoors. Stay away from exhaust gases at all times.*
- *Start the engine only using the spinner driver and an electric starting device.*
- *Keep clear of the safety guard. NEVER stick your fingers or anything else through the safety guard.*

- *Only make engine adjustments when the engine is not running. Stop the engine by fully closing the carburetor.*
- *Avoid touching the cylinder head or the exhaust pipe as this may cause serious burns*

### STARTING PROCEDURE

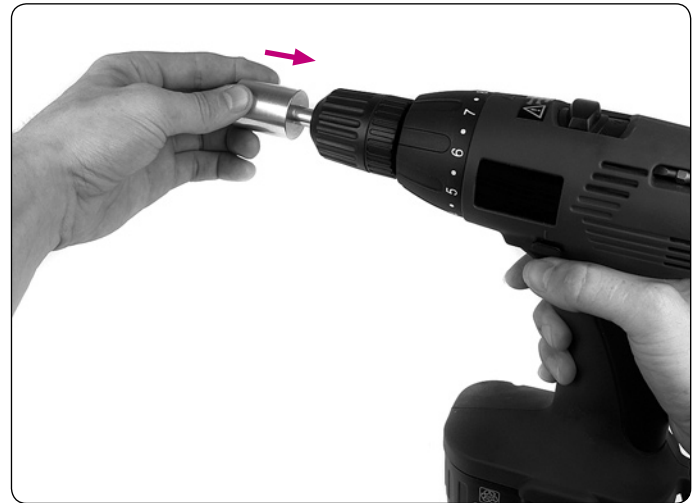

1. *Securely mount the spinner driver in an electric drill, and then put the rubber insert in the end of the spinner driver. Set the drill to “reverse” direction (counter-clockwise). A minimum of 2000RPM is required to start the engine.*

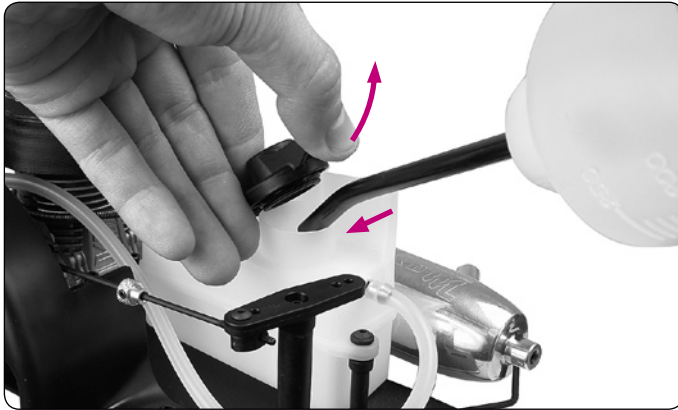

**2. Fill the fuel tank.**

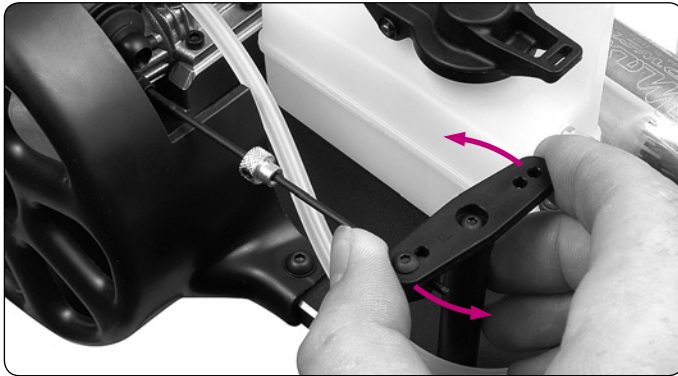

**3. Open the carburetor to 2mm using the throttle linkage.**

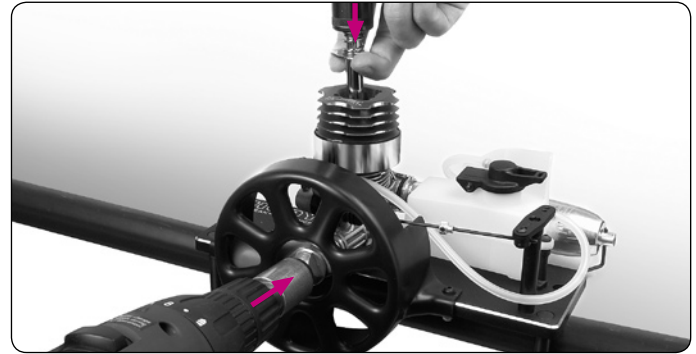

**4. Apply the glowplug starter to the glowplug, press the spinner driver firmly against the spinner, and turn on the drill (running CCW or "reverse").**

**5. If the engine does not fire up within 5sec, try doing the following:**

**a. Check the fuel line to see if fuel is reaching the carburetor. If fuel is not reaching the carburetor, remove the glowplug starter, cover the exhaust tailpipe and "dry-start" the engine for 2sec. This will build up extra pressure in the pipe and in the pressure line to the fuel tank, causing the fuel to be pushed to the carburetor. Apply the glowplug starter and try to start the engine again.**

**b. Unscrew the glowplug to check if the engine is getting any fuel. The glowplug should be slightly wet. If it is still dry, open the main needle another 1/2 turn richer (CCW). Reinstall the glowplug and try to start the engine again.**

## BREAK-IN PROCESS

c. The glowplug may also be too wet. Start the engine without the glowplug in place, for about 5sec, with the throttle fully open. Fuel will escape through the glowplug hole in the cylinder head; place a towel over the cylinder head while doing this to avoid getting fuel over everything. Close the main needle ¼ turn. Reinstall the glowplug and try to start the engine again.

6. Once the engine has started, apply a bit of throttle and allow the engine to warm up to operating temperature (approximately 1min). This is an important routine that you should always follow. The internal parts need to receive lubrication and reach operating temperature.

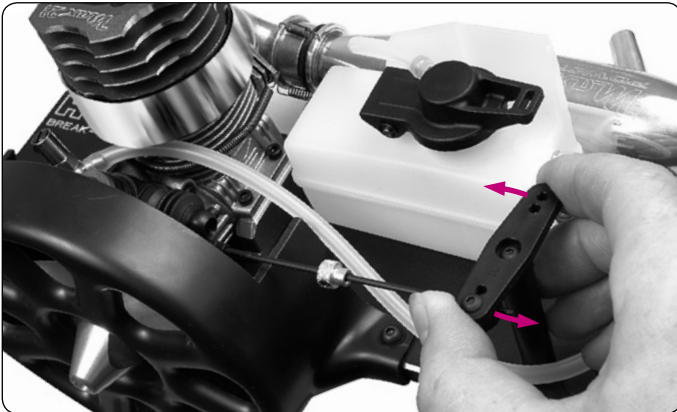

A nitro-powered engine requires careful break-in the first time the engine is used to allow the internal parts to achieve proper operating clearances. This is especially true of the piston/cylinder, crankshaft, and conrod. Pay close attention during the initial break-in period; this process is very important to achieve the best engine performance, reliability, and lifespan.

The proper way to break in this nitro engine is to “heat cycle” the engine with short periods of running followed by cooling down periods. Heat cycling allows the engine to heat up to its optimum operating temperature, allowing the components to “wear in” to each other properly. During the running time, the engines should be run only **SLIGHTLY** rich; overly-rich mixtures and cold temperature break-in will lead to premature wear and failure of the piston & sleeve and other engine components.

After installing the engine in the HUDY Engine Break-In Bench and performing the break-in preparation, then break in the engine by performing the following steps:

1. Keep the carburetor factory settings; do not adjust.
2. Start the engine and allow it to reach operating temperature.

- 3. For the first tank of fuel, run the engine at 25% throttle.**

*The engine should run very slightly rich. If not, stop the engine by closing the throttle completely and pinching the fuel line with needle-nose pliers... being careful not to damage the fuel line or get the pliers near the spinning propeller. Adjust the main needle and finish the remainder of the first 10min break-in period.*

- 4. Stop the engine and allow it to cool down completely. Make sure the piston does not get stuck at TDC (top dead center — at the top of the cylinder); rotate the propeller by hand to move the piston to the bottom of its stroke (BDC — bottom dead center).**

- 5. Run the engine through several more heat cycles:**

- a) more tanks of fuel at 50% throttle (the engine should still be running slightly rich), with complete cool-downs.
- b) more tank of fuel at 70% throttle (the engine should be running crisply now), then complete cool-down.

*During the final tank of fuel, vary the throttle and check the crispness of the engine response.*

## ENGINE TEMPERATURE

*Throughout the break-in process, regularly check the engine temperature to ensure it stays within the range of 200—250°F. This is only a guideline and may vary from engine to engine. The engine temperature and RPM should be steady and not vary significantly; any significant changes indicate that the carb settings require attention.*





## TROUBLESHOOTING

### ENGINE SPINS BUT WILL NOT START

- *Make sure your glowplug starter is fully charged and is properly connected to the glowplug. If the starter is fully charged, replace the glowplug.*
- *Verify that fuel is getting to the carburetor. Remove the fuel line from the carburetor and see if there is fuel in it.*
- *Check your carb settings. It may be necessary to adjust the carb settings if the weather has significantly changed since the last time you ran the engine.*
- *The engine's compression may be low due to wear. This will make the engine difficult to start when it is warm, and may tend to stall when running and when the throttle is closed suddenly.*

### ENGINE WILL NOT SPIN (WHEN APPLYING SPINNER DRIVER)

- *The engine may be flooded and hydraulically locked.*
- *Check for binding at the engine flywheel. If you are not able to turn the engine by hand, the engine could be flooded, the piston may be stuck at the top of the cylinder (TDC), or there could be internal engine damage. (Note: During engine break-in, it is normal for the engine to be extremely tight and hard to turn when the piston reaches the top of the cylinder.)*

### ENGINE IS VERY SLUGGISH, HARD TO START, AND WILL NOT IDLE DURING INITIAL BREAK IN

- *The factory default break-in settings (on the carburetor) may be too rich for your location, weather conditions, or fuel brand. Extremes in temperature, humidity, barometric pressure, and altitude cannot always be accounted for by the factory default settings. These symptoms may occur when air density is very low (such as in high mountains or extremely cold temperatures. Under these conditions, lean the main needle valves slightly (1/8 turn CW), and check if there is any improvement in starting and idling. Only lean the main needle until the engine runs and idles reliably, then continue the break-in process.*
- *Different fuel brands/types—in combination with extreme weather conditions—can also make the factory default break-in settings too rich and cause these symptoms. Try leaning the fuel mixture slightly (1/8 turn CW), and check if there is any improvement in starting and idling.*

## ENGINE PERFORMANCE IS SLUGGISH

- *Engine performance depends on the carb settings and how they compensate for the weather & atmospheric conditions. Before suspecting other issues, richen the main needle by at least  $\frac{1}{4}$  turn **CCW**, then retune the engine.*
- *Try installing a new glowplug.*
- *If carb settings are proper, ensure the fuel is fresh. Old fuel, or fuel that has been left uncapped for a long period, may cause sluggish performance.*

## PISTON STUCK AT TOP OF CYLINDER—TOP DEAD CENTER (TDC)

- *A brand new engine that has not had a lot of break-in will typically have a very tight fit between the piston and the top of the cylinder (known as “pinch”), since the cylinder has a tapered fit. The fit should not be so tight that then engine cannot be started. If the piston gets stuck at **TDC**, use a pair of pliers to grasp the flywheel from the bottom of the engine. Rotate the flywheel **CCW** (viewed from the front of the engine) until the flywheel turns; you should feel the piston become unstuck from the top of the cylinder.*

## WARRANTY

*This product is guaranteed to be free from defects in materials and workmanship for a period of 1 year from the date of purchase when returned for service accompanied by proof of purchase (register receipt, credit card invoice, etc.).*

*Damage caused by customer disassembly/assembly, modification of components, improper use, or any use of the product for other than its specific intended use will automatically void this warranty.*

## NOTES

[team@hudy.net](mailto:team@hudy.net)  
**www.hudy.net**



**HUDY, Pred Polom 762, 91101 Trencin, Slovakia, Europe**